

V7

Digital speed to fly variometer and final glide calculator

Version 4.00



LXNAV d.o.o. • Kidričeva 24a, 3000 Celje, Slovenia • tel +386 592 33 400 fax +386 599 33 522
info@lxnav.com • www.lxnav.com

1	Important Notices	4
1.1	Limited Warranty	4
2	Packing Lists	5
3	Basics	6
3.1	LXNAV V7 at a Glance	6
3.1.1	LXNAV V7 Features	6
3.1.2	Interfaces	7
3.1.3	Options	7
3.1.3.1	External Options	7
3.1.4	Technical Data	7
4	System Description	8
4.1.1	Push Button	8
4.1.1.1	Power Button	8
4.2	Rotary Switch	8
4.3	Switching on the Unit	9
4.4	User Input	9
4.4.1	Text Edit Control	10
4.4.2	“Spin” Control	10
4.4.3	Selection Control	10
4.4.4	Checkbox and Checkbox List	10
4.4.5	Slider selector	11
4.5	Switching off	11
5	Operating Modes	12
5.1	Main screen and needle	12
5.1.1	Flarm Warning	13
5.1.2	Direct link between PDA and GPS	13
5.2	Quick access menu	14
5.3	Settings Mode	15
5.3.1	Navigate	15
	Target information can be received from PDA or GPS.	16
5.3.2	Logbook	16
5.3.3	QNH and RES	17
5.3.3.1	QNH	17
5.3.3.2	Safety Altitude	17
5.3.3.3	Set elevation	17
5.3.4	Vario Parameters	18
5.3.4.1	Some definitions	19
5.3.4.2	Vario needle filter	19
5.3.4.3	Vario sound filter	19
5.3.4.4	Netto filter	19
5.3.4.5	Relative filter	19
5.3.4.6	SC filter	19
5.3.4.7	Smart Filter	20
5.3.4.8	Needle range	20
5.3.4.9	Dead Band (SC tab)	20
5.3.4.10	Auto SC	20
5.3.4.11	SC switch	20
5.3.4.12	Vario Average Time	21
5.3.4.13	Netto Average Time	21
5.3.4.14	Auto reset integrator	21
5.3.4.15	TE compensation	21

5.3.4.16	Temperature Offset	22
5.3.4.17	Inertial assisted vario	22
5.3.5	Sounds	22
5.3.5.1	Sounds settings	23
5.3.5.2	Equalization	25
5.3.6	Units	26
5.3.7	Display	27
5.3.8	Communication	28
5.3.8.1	Bluetooth on PDA port	28
5.3.9	Polar and Glider	30
5.3.10	Flarm	31
5.3.11	Password	31
5.3.12	Reset of accelerometer (g-meter)	32
5.3.13	About	32
6	Variometer and Altimeter	33
	Altimeter	33
6.1	Speed Command	33
7	Flying with the LXNAV V7	34
7.1	On the Ground	34
7.1.1	Power on Procedure	34
7.1.2	Set Elevation and QNH	34
7.1.3	Pre-flight Check	35
7.2	Airborne	35
7.2.1	Final glide calculation	35
8	Installation	36
8.1	Installing the LXNAV V7	37
8.2	Connecting LXNAV V7	37
8.3	Cutout of V7	37
8.4	Installation of options	38
8.4.1	Ports and Wiring	38
8.4.1.1	LXNAV V7 ports	38
8.4.1.2	LXNAV V7 wiring	40
8.4.2	Configurations	40
8.4.2.1	NANO – V7 – OUDIE	40
8.4.2.2	NANO3 – V7 – MINIMAP	41
8.4.2.3	COLIBRI2 – V7 – OUDIE	41
8.4.2.4	COLIBRI,VOLKSLOGGER– V7 – OUDIE	41
8.4.2.5	Flarm/RedBox– V7 – OUDIE	41
8.4.2.6	FlarmMouse - FlarmView -V7 - OUDIE	42
8.4.2.7	FlarmMouse – V7 – OUDIE	42
8.4.3	V7D option (V7 repeater)	43
9	Firmware Update	44
9.1	Updating LXNAV V7 firmware using OUDIE	44
9.2	Updating LXNAV V7 firmware using PC	45
10	Options	47
10.1	Rear Seat Device (LXNAV V7D)	47
10.1.1	Data Exchange	47
10.1.2	Cable Wiring (LXNAV V7D)	47
10.2	Available cables for GPS and PDA ports	47
11	Revision History	48

1 Important Notices

The LXNAV V7 system is designed for VFR use only as an aid to prudent navigation. All information is presented for reference only. Terrain, airports and airspace data are provided only as an aid to situation awareness.

Information in this document is subject to change without notice. LXNAV reserves the right to change or improve their products and to make changes in the content of this material without obligation to notify any person or organisation of such changes or improvements.



A Yellow triangle is shown for parts of the manual which should be read carefully and are important for operating the LXNAV V7 system.



Notes with a red triangle describe procedures that are critical and may result in loss of data or any other critical situation.



A bulb icon is shown when a useful hint is provided to the reader.

1.1 Limited Warranty

This LXNAV V7 product is warranted to be free from defects in materials or workmanship for two years from the date of purchase. Within this period, LXNAV will, at its sole option, repair or replace any components that fail in normal use. Such repairs or replacement will be made at no charge to the customer for parts and labour, the customer shall be responsible for any transportation cost. This warranty does not cover failures due to abuse, misuse, accident, or unauthorised alterations or repairs.

THE WARRANTIES AND REMEDIES CONTAINED HEREIN ARE EXCLUSIVE AND IN LIEU OF ALL OTHER WARRANTIES EXPRESSED OR IMPLIED OR STATUTORY, INCLUDING ANY LIABILITY ARISING UNDER ANY WARRANTY OF MERCHANTABILITY OR FITNESS FOR A PARTICULAR PURPOSE, STATUTORY OR OTHERWISE. THIS WARRANTY GIVES YOU SPECIFIC LEGAL RIGHTS, WHICH MAY VARY FROM STATE TO STATE.

IN NO EVENT SHALL LXNAV BE LIABLE FOR ANY INCIDENTAL, SPECIAL, INDIRECT OR CONSEQUENTIAL DAMAGES, WHETHER RESULTING FROM THE USE, MISUSE, OR INABILITY TO USE THIS PRODUCT OR FROM DEFECTS IN THE PRODUCT. Some states do not allow the exclusion of incidental or consequential damages, so the above limitations may not apply to you. LXNAV retains the exclusive right to repair or replace the unit or software, or to offer a full refund of the purchase price, at its sole discretion. SUCH REMEDY SHALL BE YOUR SOLE AND EXCLUSIVE REMEDY FOR ANY BREACH OF WARRANTY.

To obtain warranty service, contact your local LXNAV dealer or contact LXNAV directly.

March 2012

© 2012 LXNAV. All rights reserved.

2 Packing Lists

- LXNAV V7 (in Metric or Imperial units as specified)
- Main power cable for V7 + CAN terminator
- Speaker
- GPS cable - V7-GPS-IGC



3 Basics

3.1 LXNAV V7 at a Glance

LXNAV V7 is standalone digital vario meter and final glide calculator with GPS and PDA/PNA inputs/outputs. The unit has standard dimensions to fit into a glider panel - 57 mm diameter (2¼"). It is also able to supply PDA/PNA with power (5VDC/1A). The unit has integrated high precision digital pressure sensors, which are sampled more than 100 times per second. Data is indicated with needle driven with stepper motor and displayed on 320*240 pixel, two-inch, high brightness colour display. To adjust values and settings, LXNAV V7 has one rotary knob combined with a push button.

LXNAV V7 can be expanded through CAN bus to one or more repeaters (LXNAV V7D). Both pilots can have equal control of all functions from front or rear seat.



3.1.1 LXNAV V7 Features

- Extremely bright 2" (5 cm) colour display readable in all sunlight conditions with the ability to adjust the backlight .
- One rotary switch (knob) with push button function is used for input.
- Pre-loaded polar database for almost all gliders.
- GPS and PDA inputs/outputs
- Flarm Indication, if Flarm is connected to the GPS port
- Mechanical needle driven by stepper motor indicating various data such as netto vertical speed, relative (super netto) and vertical speed.
- 240x320 pixels colour screen for additional information such as average, thermal vario, time, speed etc...
- Many custom audio settings
- 100Hz sampling rate for very fast response.
- Speed to fly indication.

- TE compensation can be selected to be either pneumatic TE probe or electronic TE.
- Multilanguage user interface
- Audio equalizer, for better vario sound performance

3.1.2 Interfaces

- GPS port input/output on RS232 level (Standard IGC RJ11 connector)
- PDA port input/output on RS232 or LV-TTL (3.3V) level for PNA devices (RJ45 connector)
- Audio port (Standard 3mm phono jack)
- 1Mbit CAN bus for extension to V7D repeater

3.1.3 Options

3.1.3.1 External Options

By using a CAN bus system a second seat device can be connected. The unit installed in the rear seat of the glider is independently powered and receives all necessary data from the main unit. The communication between both units is exclusively via the CAN bus system.

3.1.4 Technical Data

- Power input 10-16 V DC
- Consumption of LXNAV V7 at 12 V:
 - 120 mA - minimum brightness without audio.
 - 180 mA - maximum brightness without audio.
- Consumption of LXNAV V7D at 12 V:
 - 90 mA - maximum brightness without audio.
- 57 mm (2¼") standard aircraft cut-out for the LXNAV V7 vario unit; length 95 mm (not including connector).
- Weight 330g (160g for V7D)

4 System Description

4.1.1 Push Button

The Rotary switch also has a push button function. LXNAV V7 can detect short or long press of push button, in most cases short press confirms action, long press cancels action or exits from the menu. Short press means just a click, long press means pushing button for more than one second.

4.1.1.1 Power Button

The system is powered up using push button. A long press system will turn the V7 off.

4.2 Rotary Switch

The one rotary switch/knob with integrated pushbutton function can control all functions on LXNAV V7. The rotary switch moves up or down through the menus. Variables can also be changed using the switch. Pushing the button at the same time as rotating will step the values in larger increments.

Example 1:

Set elevation menu; normally, values are with step 1m. If you push button in and rotate at same time, the step will be 10m.

Example 2:

Entering password; Up/Down the numbers are changed. If you press and rotate, the cursor will move left or right. Short press will move cursor one step right.



Rotary switch with push button

4.3 Switching on the Unit

A short press of the button with turn on the V7. The first LXNAV welcome screen will appear with some system information (Device name, Version, Serial number...)



V7D cannot be powered up if V7 is not already powered up.

When the boot procedure is completed, setup elevation dialogue is shown.



By default setting Set Elevation page is disabled. It can be enabled in Setup QNH&RES menu.

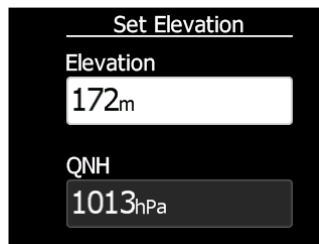

Push button also has power ON and OFF functions.

4.4 User Input

The LXNAV V7 user interface consists of many multi language dialogues which have different input controls. They are designed to make input of names, parameters, etc., as easy as possible. Input controls can be summarised as:

- Text editor
- Spin controls (Selection control)
- Checkboxes
- Slider control

To move the function from one control to another, rotate the rotary knob up or down as follows:

- Clockwise rotation will select the next control.
- Counter clockwise rotation will select the previous control. PUSH button enters the selected feature.

4.4.1 Text Edit Control

The Text Editor is used to input an alphanumeric string; the picture below shows typical options when editing text. Use the knob to change the value at the current cursor position.

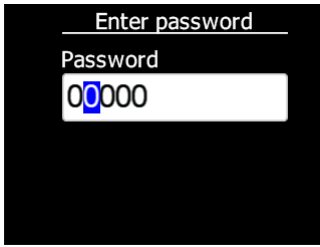

Push button will move cursor right. Holding push button and rotating knob, will move cursor left or right. At last character position, push button will confirm edited value, long press will cancel editing and exit that control.

4.4.2 "Spin" Control

"Spin" controls are designed for numeric parameters. Rotate the knob to increase/decrease the selected value. Combination of push button and knob rotation will change the value with a larger step. .

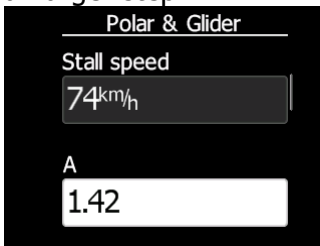

4.4.3 Selection Control

Selection boxes, also known as combo boxes are used to select a value from a list of predefined values. Use the page selector to scroll through the list.

4.4.4 Checkbox and Checkbox List

A checkbox enables or disables a particular parameter. Press **push button** to toggle the value. If an option is enabled a check mark will be shown, otherwise an empty rectangle will be displayed.

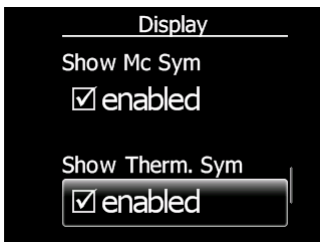

4.4.5 Slider selector

Some values like volume and brightness are displayed as a slider

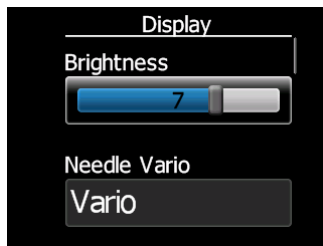

With push button you can activate slider control, then with rotation of the knob you can select the preferred value and confirm it with the push button.

4.5 Switching off

By pressing the push button for app. 5 seconds, LXNAV V7 will turn off. Same procedure is for V7D, if V7D is on and we are attempting to switch off V7, V7D will also switch off.



All settings are saved in the power off procedure. We strongly recommend switching off the unit using push button and not use a separate master switch..



If the system is powered off by a master switch changed data will not be saved. Flight parameters at takeoff like target altitude and position will remain in stored memory so your final glide calculations are not affected.

5 Operating Modes

LXNAV V7 has three operating modes. A pilot has access to all of them using rotary knob and push button. The diagram below shows the mode structure of the LXNAV V7.

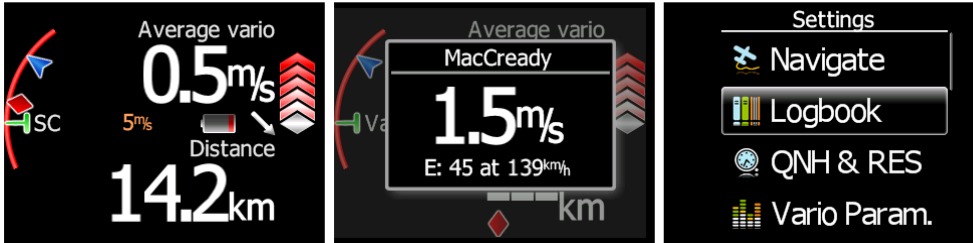

- **Main screen**, all navigation and flight parameters defined by pilot
- **Quick access**, MacCready, Ballast, Bugs, Distance (in manual navigation without GPS) and Wind component (in manual navigation).
- **Settings**, setup of the whole system

5.1 Main screen and needle

The main screen has a mechanical needle and a 320x240 color display with user selected data.

Description of LXNAV V7 is shown on next picture.

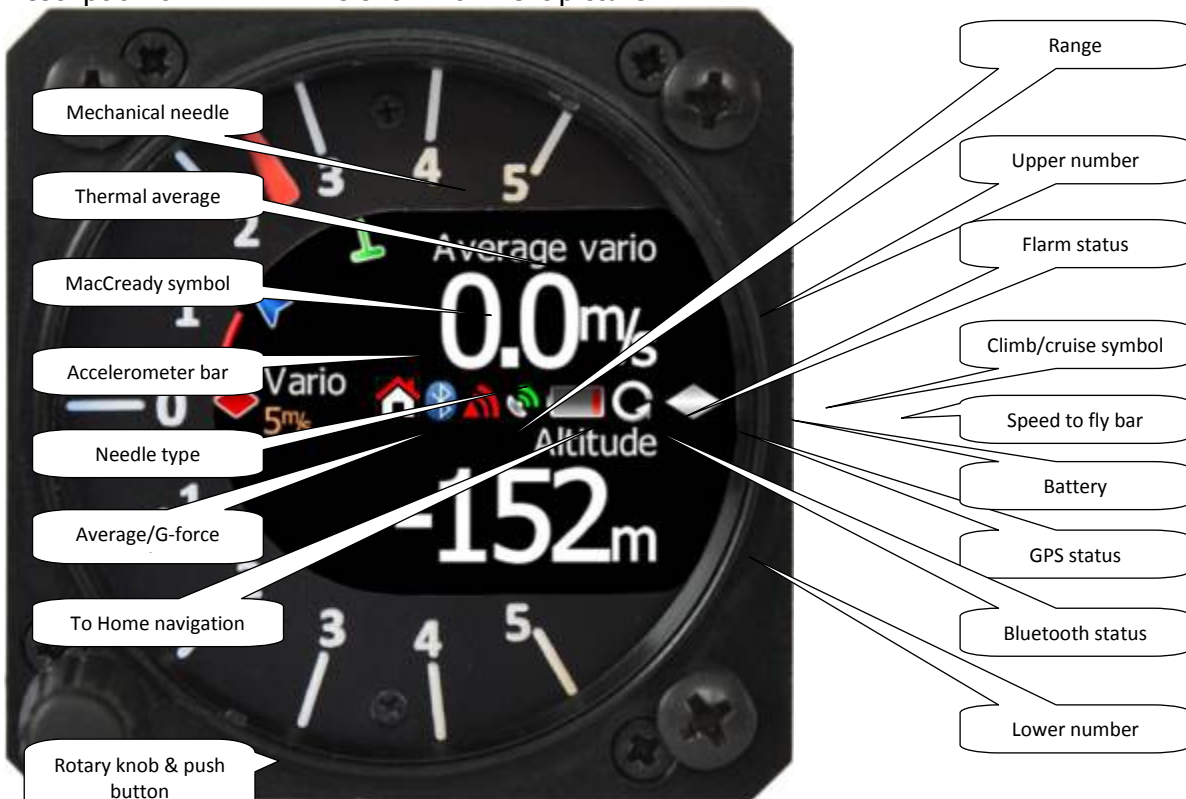

Mechanical needle displays vario, netto, relative or speed to fly value. It can be setup scale can be chosen (when ordered) in the range of -5 to 5 or from -10 to 10. Within the software the range can be set to 2.5, 5, 10m/s or 5, 10, 20kts or 500, 1000, 2000fpm.

Upper number can be configured as average vario, time, flight time, task remaining time, netto value, outside temperature or thermal average, steering course. It can be setup separately for climb mode or cruising mode.

Lower number shows current altitude, distance to goal, arrival altitude, true airspeed, Last 60 minutes speed, altitude in feet or flight levels.

Speed to fly bar symbol is indicating which speed you have to fly according to current MacCready setting, sink rate and speed. One arrow means 10units of speed faster or slower. Up red arrows mean fly slower and down blue arrows mean fly faster.

Red diamond symbol can show average vertical speed or g-force.

Blue arrow symbol shows current MacCready value.

Green T symbol represents last thermal average value.

White bar, which is not shown on the picture above, displays arc between minimum and maximum vertical speed value in last 20 seconds.

In LXNAV V7 there is an integrated 3 axis +-6g accelerometer. All accelerations can be recorded and indicated with accelerometer red bar. **Red bar**, which is not shown on picture above, displays maximum negative and positive acceleration in g.

BlueTooth symbol indicates detected BluetoothModule for V7 on PDA port.

Flarm symbol indicates presence of flarm device (pink) and also detection of flarm traffic (red).

5.1.1 Flarm Warning

If Flarm warnings are enabled the following is a typical screen display:

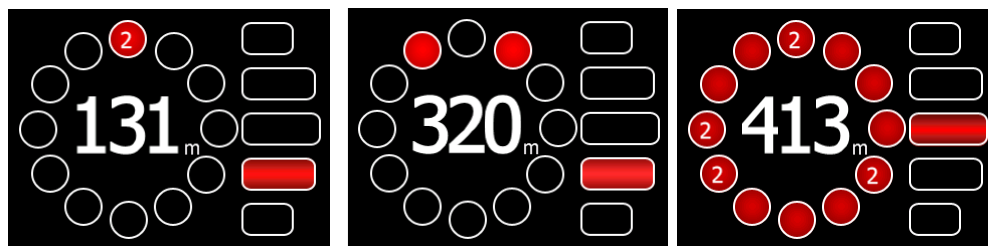

The screen indicates relative position of threat. In the first image two gliders are approaching inbound below, the second screen two gliders are approaching inbound, one on left side and another the right. On third image we have active "undirected warning" together with other flarm warnings with known direction.

5.1.2 Direct link between PDA and GPS

LXNAV V7 is able to make direct link connection between PDA and GPS. Normally GPS and PDA communicate with LXNAV V7. In the direct link mode the user can transfer data from PDA to GPS (Flight recorder) or the opposite way (read the flight). The direct link is normally initiated by software such as SeeYou Mobile or ConnectMe.

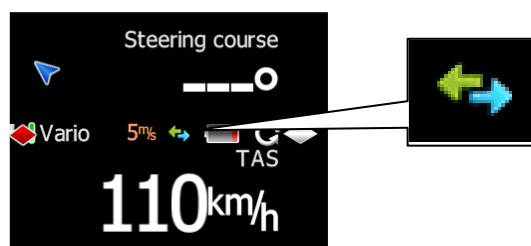

The picture above indicates a direct link. This happens automatically when PDA send a request for direct communication with flight recorder.

See tutorial on: http://youtu.be/nMZI7cJ_qjQ

5.2 Quick access menu

A short press of the push button activates the quick access menus. If "use GPS navigation" is checked, only three Mc, Bugs and Bal are available. If "use GPS navigation" is disabled two additional settings are available (Wind component and distance).

In the last row of the box is calculated final glide (E) and required speed for that final glide, values depends on MacCready, Bugs and Ballast setting.

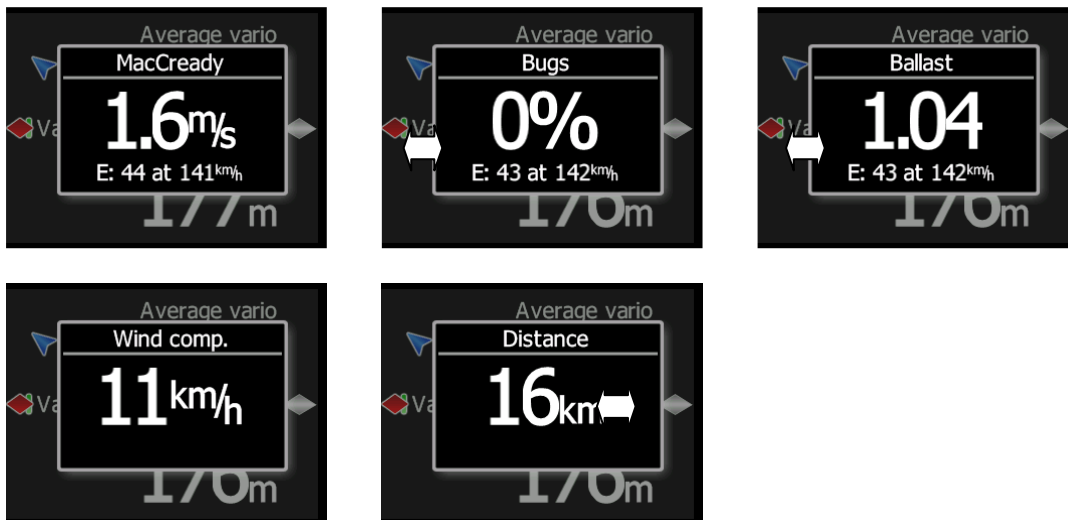

5.3 Settings Mode

In the setup menu users can configure the LXNAV V7. Turn the knob to select the appropriate setup item. Press the **PUSH** button to enter a menu. A dialogue or sub-menu will open.

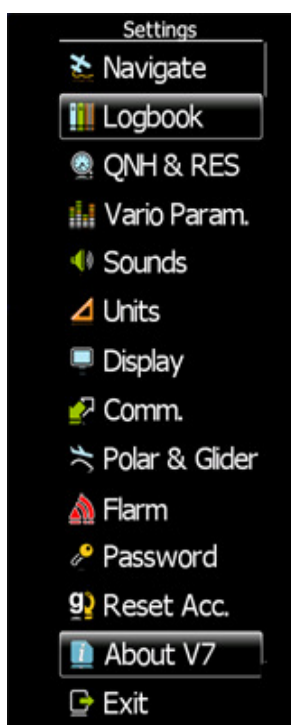

5.3.1 Navigate

In this menu navigation settings can be configured.

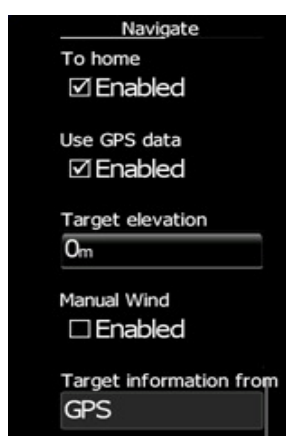

If **Navigate to home** is enabled, LXNAV V7 will navigate back to the takeoff point. This position has been stored in memory just before takeoff but only if GPS OK status is showing. Navigate to home will not work if **“use GPS data”** is not checked.



Use GPS data, enables the V 7 to receive GPS data on GPS port. If **Use GPS data** is disabled manual navigation will be active, in that case GPS icon on main screen will not be displayed. It means that pilot must manually enter distance and wind component (See Chapter 5.2). If GPS is transmitting RMB sentences, LXNAV V7 will automatically calculate final glide to that point. On picture below LXNAV V7 navigates to waypoint "Line 11".



Be sure that you set correct target elevation. If target elevation is not set, LXNAV V7, will not show **Arrival altitude**, but **Required altitude**. Required altitude is the altitude that will be lost for the required distance.



GPS data will be received only if baudrate on GPS side is set at the same value as set on LXNAV V7 in Comm. Menu. (See Chapter 5.3.8)

Target elevation set to elevation of your departure. It can be adjusted any time.

Manual wind can be checked, when pilot wants to insert fixed value of wind component. In that case V7 will not use it's calculated wind for final glide calculations, but manual entered.

Target information can be received from PDA or GPS.

5.3.2 Logbook

Each flight is stored in logbook.

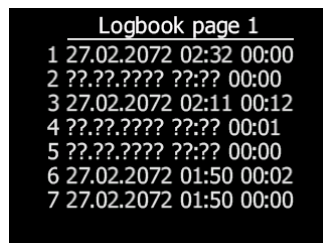

If GPS data is present the logbook will show present date and time of departure. Manual navigation (without GPS) will show duration and departure time will be marked with question marks.

5.3.3 QNH and RES

Turn the knob to select the required entry field. Press the **PUSH** button and start editing the value.



5.3.3.1 QNH

This feature may be used to offset the altitude datum as the result of pressure changes during the flight. Since changing the QNH influences the indicated altitude, care should be taken when changing the value as an incorrect setting could upset the final glide calculation.

5.3.3.2 Safety Altitude

This setting is the altitude reserve or safety altitude and is the height that the instrument adds to the final glide altitude required so the glider arrives over the final glide destination at the selected safety altitude. Once the safety altitude has been specified, the pilot has to keep the final glide indicator on 0 to arrive at the safety altitude.

5.3.3.3 Set elevation

If Set Elevation – show on start-up, item is not checked, Set elevation menu, will not be displayed during start up. In this case elevation will be set to standard QNE (Flight level).

5.3.4 Vario Parameters

This option is used to set the following parameters:

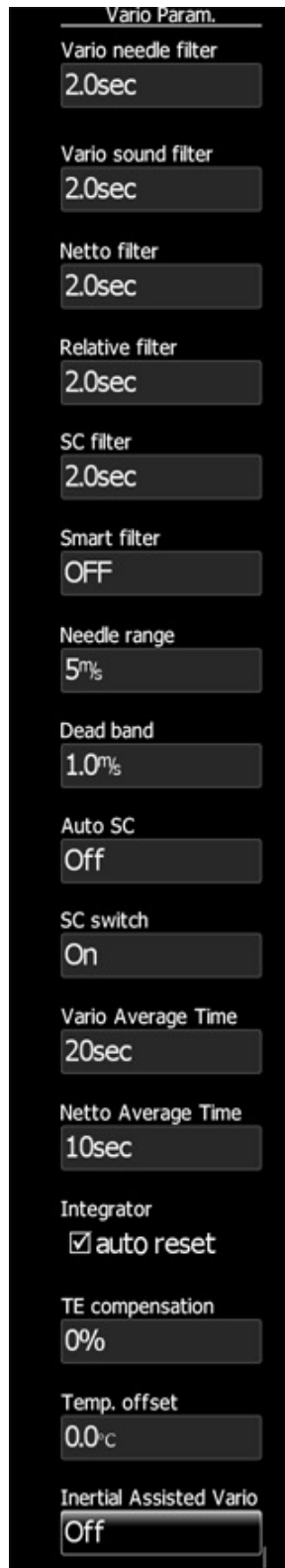

Vario Param.

Vario needle filter	2.0sec
Vario sound filter	2.0sec
Netto filter	2.0sec
Relative filter	2.0sec
SC filter	2.0sec
Smart filter	OFF
Needle range	5 ^m / _s
Dead band	1.0 ^m / _s
Auto SC	Off
SC switch	On
Vario Average Time	20sec
Netto Average Time	10sec
Integrator	<input checked="" type="checkbox"/> auto reset
TE compensation	0%
Temp. offset	0.0°C
Inertial Assisted Vario	Off

5.3.4.1 Some definitions

Vario

Vario is defined as the measurement of the gliders vertical speed. This signal is generally total energy compensated, what means that parts of the signal, coming from the change in the gliders horizontal speed (Conversion from kinetic energy into potential energy and vice versa), are taken out. This can be done by a TE tube or arithmetical (electronically compensation)

Netto

From the vario signal the vertical speed of the air mass is calculated, by taking into account the gliders parameter (polar and weight) and current horizontal speed (IAS).

Relative

If you subtract the gliders sinkrate while circling from Netto, you will get the vario value which you would see, when starting to circle ideally at the current position. This value is called Relative. The sinkrate is taken from the polar for straight flight, therefore the Relative value is a little bit optimistic

Speed to fly

There are two terms in use:

Speed to Fly (STF) is the speed one should fly at given parameters like MacCready setting, polar, weight/wing load and current vertical speed, to be optimal in time between the thermals according to the MacCready theorie.

Speed Command (SC) is the interpretation of the STF in a needle and/or audio signal, which shows the difference to the ideal STF in a way, that the pilot can interpret it as a steering command (push/pull).

5.3.4.2 Vario needle filter

Sets a time constant of the vario needle. The value can be adjusted between 0.1 and 5 s with step 1.0 s or 0.1 s. Default value is 1.5 s.

5.3.4.3 Vario sound filter

Sets a time constant of vario sound. The value can be adjusted between 0.1 and 5 s with step 1.0 s or 0.1 s. Default value is 1.5 s.

5.3.4.4 Netto filter

Sets a time constant of the **Vario Netto** needle. The value can be adjusted between 0.1 and 5 s with step 1.0 s or 0.1 s. Default value is 1.5 s.

5.3.4.5 Relative filter

Sets a time constant of the **Vario Relative** needle. The value can be adjusted between 0.1 and 5 s with step 1.0 s or 0.1 s. Default value is 1.5 s.

5.3.4.6 SC filter

Sets a time constant of the **SpeedToFly** needle. The value can be adjusted between 0.1 and 5 s with step 1.0 s or 0.1 s. Default value is 1.5 s.

5.3.4.7 Smart Filter

The Smart Filter allows additional filtering of the vertical speed. It defines the difference between increasing vertical speed versus decreasing vertical speed. (E.g.: If the vario filter is set to 1s and the Smart Filter set to 4s, the filtering for increasing vario would be 1s and for decreasing vario would be 2s. This will produce an effect similar to a Sage Variometer.)

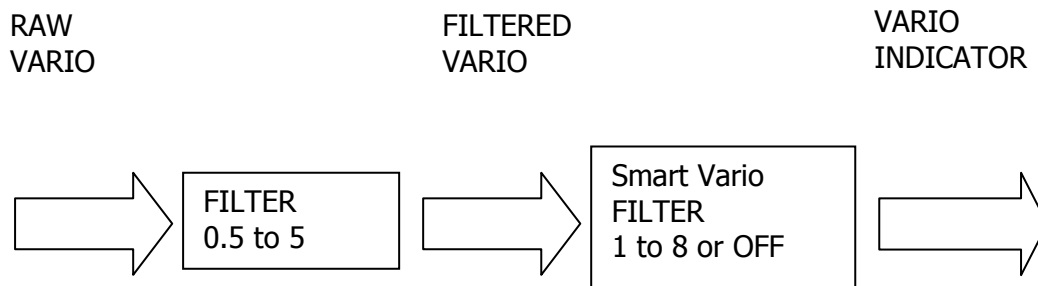

5.3.4.8 Needle range

Sets full scale range of the vario (2.5 m/s, 5 m/s or 10 m/s). Default value is 5 m/s (10 kts).

5.3.4.9 Dead Band (SC tab)

Defines the width of the audio dead band in speed to fly mode. Default value is ± 1 m/s.

5.3.4.10 Auto SC

Defines the conditions when the instrument will switch automatically between vario and speed to fly mode.

- **OFF:** Switching is exclusively by an external switch connected to the V7.
- **GPS:** When the GPS detects that the glider is circling an automatic change over to vario will happen after approximately 10 seconds. Detection of straight flight will cause a changeover to speed command.
- **TAS:** When the TAS exceeds a pre-set value. The TAS at which switching occurs can be selected in 5 km/h steps from 100 up to 160 km/h (or the equivalent in knots or mph).
- **G-meter** – for switching between cruise and climb mode will be used inertial system. When glider will start circling, V7 will automatically switch from cruise to climb mode.



The external switch wired to the LXNAV V7 has absolute priority and will override all other switching methods.

5.3.4.11 SC switch

The LXNAV V7 has an input for an external **speed command switch**. Using the external switch it is possible to switch between SC and Vario manually. Setting the **SC switch** to **ON** means that closing the switch will cause the instrument to enter SC mode and setting SC switch to **OFF** means that closing the switch will select Vario mode. There is a third option by setting SC INPUT to **TASTER** and connecting a push button to the input; each key press will toggle between SC and Vario (mandatory setting for LX Remote).



There is another input called VARIO PRIORITY. When this input is activated by grounding the appropriate wire the unit will change over to Vario immediately. This input wire is set open (not grounded) as a factory default on delivery.

5.3.4.12 Vario Average Time

Defines the integration period for the average vario in seconds. The default is 20 seconds.

5.3.4.13 Netto Average Time

Defines the integration period for the average netto vario in seconds. The default is 10 seconds.

5.3.4.14 Auto reset integrator

Resets the integrator to zero when the V7 vario unit switches from SC to VARIO mode. If this item is not checked the integrator will not be reset to zero.

5.3.4.15 TE compensation

The LXNAV V7 offers two methods of vario Electronic Total Energy Compensation:

- TE Pitot tube
- Electronic TE compensation



It is important to note that the method of TE compensation is set up when the instrument is installed by virtue of the pneumatic connections made to the TE and static ports. Changing the compensation type in the setup screen below WILL NOT change the method of compensation - the pneumatic plumbing has to be changed first.



If the TE pitot tube has been connected TE compensation should be set to 0%. There is no further adjustment of TE compensation possible. Quality of the TE tube is the one and **only** factor.



If the electronic TE option has been installed TE compensation should be set to 100%.

The electronic TE compensation can be fine-tuned during flight using the following procedure: it is essential that this is only done in smooth air; it is not possible to tune the TE accurately in turbulent air.

Set TE compensation to 100%. Accelerate up to approximately 160 km/h (75 kts) and keep the speed stable for a few seconds. Gently reduce the speed to 80 km/h (45 kts). Observe the vario indicator during the manoeuvre. At 160 km/h the vario will indicate about -2 m/s (-4 kts). During the speed reduction the vario should move towards zero and should never exceed zero (slightly positive indications are acceptable). If the vario shows a climb the compensation is too low; increase the TE%; and vice versa. Try another "zoom" to assess the change and make further adjustments if necessary.

Electronic TE compensation is only effective when the pitot tube and static sources are co-located and the pneumatic lines to the instrument are approximately the same length. The best sensor to use is the combined pitot/static Prandtl tube. If problems are experienced with the electronic TE compensation the most likely cause is the glider's static source. The static source can be checked by plumbing the pneumatic tubes for electronic compensation and then setting the TE: to 0%. In still air accelerate to approximately 160 km/h and slowly reduce the speed. Observe the vario indicator. If the static source is good the vario should immediately start to move to show a climb. If the needle firstly shows increased sink and then moves to a climb, the static source of the glider is unsuitable and there is no way to

provide successful TE compensation electronically. The use of a dedicated and accurate fin-mounted pitot/static source such as a Prandtl tube might help.

5.3.4.16 *Temperature Offset*

The LXNAV V7 is supplied with an external outside air temperature (OAT) sensor. With the offset setting it will correct static errors of temperature measurement.

5.3.4.17 *Inertial assisted vario*

With LXNAV V7 possible to adjust influence of g-force on vario. This influence is very small and can be set between 0 and 4.

5.3.5 Sounds

Sound menu is divided on two parts sound setting and Equalizer

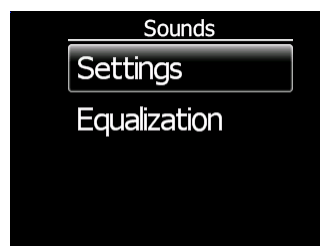

5.3.5.1 Sounds settings

In the Sounds settings menu audio settings for the LXNAV V7 and alarms settings can be modified.

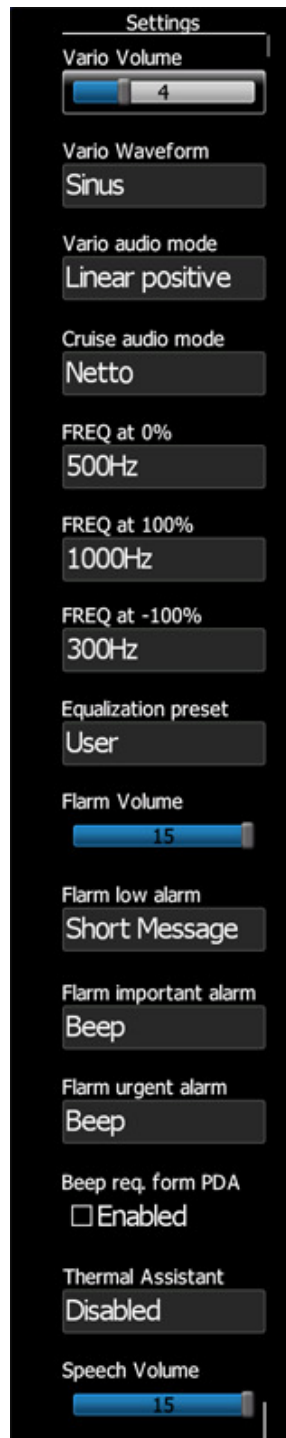

Vario Volume

The sounds slider changes the audio volume.



Volume can be also adjusted directly with rotary knob in main menu.

Vario waveform

In this setting user can change the form of audio signal. There are three options: Pure sine shape of signal, triangular or harmonic (sum of more Sine waves).

Vario Audio mode

Vario audio mode has the following options:

- **Linear positive:** sound is interrupted with silence every few milliseconds when the needle is positive; on negative side sound is linear (not interrupted).
- **Linear negative:** inverse function to **Linear positive**.
- **Linear:** sound is linear and non-interrupted in full scale range.
- **Digital positive:** similar to **Linear positive**, except frequency is not changing linearly but with larger steps.
- **Digital negative:** inverse function to **Digital positive**.
- **Linear positive only:** sound is present only at positive values, for negative values there is silence.
- **Digital positive only:** similar function to **Linear positive only**, except the sound is similar to the digital tone.

SC Audio mode

SC audio mode has four modes:

- **SC positive:** sound is interrupted with silence every few milliseconds when the needle is positive; on negative side sound is linear (not interrupted).
- **SC negative:** inverse function to SC positive.
- **SC:** sound is linear and non-interrupted in full scale range.
- **SC Mixed:** for positive relative values the sound represents relative; for negative relative values the sound represents SC (for that setting it is recommended to set SC needle to relative). Dead band is active only for negative values.
- **SC Netto:** Sound follows netto value.

Audio frequencies

- **Freq at 0%** defines the tone frequency at 0 m/s.
- **Freq at +100%** defines the tone frequency at full + deflection.
- **Freq at -100%** defines the tone frequency at full – deflection.

Equalization preset

We have three options: default LXNAV speaker, flat setting or user defined.

Flarm Volume

With Flarm volume slider the volume of flarm warning beeps can be changed.



Volume can be also adjusted directly with rotary knob in main menu but only at the moment that the **Flarm alarm is active**.

Flarm warnings

In this menu low level/important/urgent Flarm alarm types can be set. We have four options:

- Disabled
- Flarm Beep
- Short voice message
- Long voice message

Beeps requested from PDA

PDA is able to send beep command to V7, if that feature is enabled, V7 will beep on PDA request.

Thermal Assistant

Is a sound, different from other sounds from V7, which helps to the pilot in a thermal. Pilot can set, how many seconds before thermal maximum, thermal „Ping“ will be triggered.

Speech Volume

With Speech volume slider the volume of voice warnings can be changed.



Volume can be also adjusted directly with rotary knob in main menu but only at the moment that the **voice is active**.

5.3.5.2 Equalization

With rotary knob can be adjusted volume for each frequency. Setting is stored under user preset.

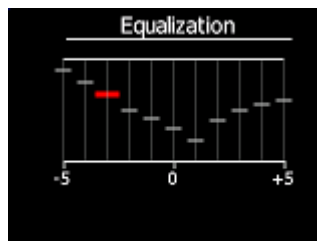

Set equalizer to flat, then find the loudest frequency and decrease it to minimum. Then adjust other frequencies to be heard at the same volume.

5.3.6 Units

Use this menu to specify units, UTC time offset and type of ballast input.ž

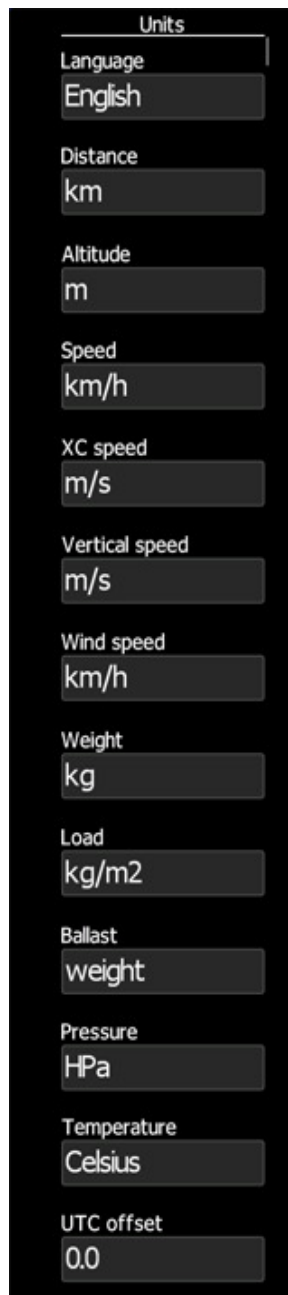

The image shows a vertical menu titled "Units" with the following settings:

Setting	Value
Language	English
Distance	km
Altitude	m
Speed	km/h
XC speed	m/s
Vertical speed	m/s
Wind speed	km/h
Weight	kg
Load	kg/m ²
Ballast	weight
Pressure	hPa
Temperature	Celsius
UTC offset	0.0

- **Load**, which is entered in kg/m² or lb/ft².
- **Weight** of water ballast, which is entered in kg or lb . If this option is used the weights of the glider and pilot must be entered. Refer to Chapters 5.3.9 for more details of how to enter glider and pilot weights.
- **Ballast** can be displayed as Overload factor or Wing Load or just weight of ballast.

5.3.7 Display

The display menu controls screen brightness.

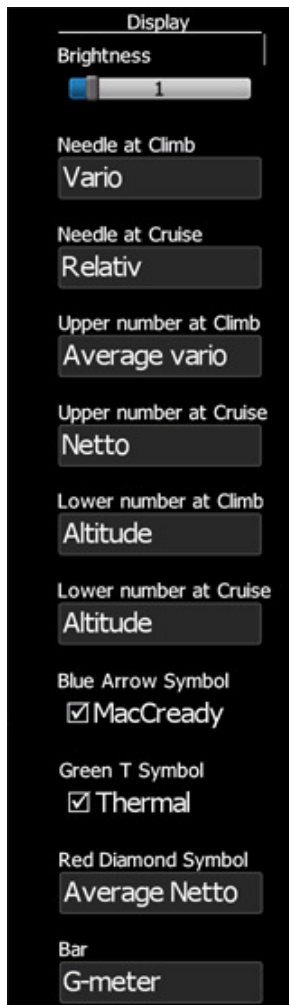

- Use **Brightness** control to adjust intensity of the LCD backlight.
- **Mechanical needle**, which can indicate vertical speed, speed to fly value, netto vertical speed, or Relative vertical speed in vario or SC mode.
- **Upper and Lower Numeric Display**: The parameter displayed can be configured separately for Vario mode and SC mode. Following parameters can be displayed: average vertical speed, local time, flight time, task remaining time, Altitude (NN altitude), Distance (distance to the navigation point), Arrival altitude (final glide altitude difference to the navigation point), Speed (TAS), Leg speed (speed on leg), QNH (ft) (NN altitude in ft), Flight levels, Outside air temperature, Battery voltage, Average NettoQFE, Total Altitude.
- **Blue Arrow Symbol** enables or disables to display MC symbol
- **Green T Symbol** enables or disables the display thermal symbol
- **Red Diamond Symbol** have three options:
 - **OFF** Red diamond is not displayed
 - **Average vario** Shows average vario
 - **G-meter** shows actual G-force (one line means 1g, the range of accelerometer indication is +/-5g, you should not look at vario dial)
- **Bar** has three options:
 - **OFF** bar is not displayed

- **MinMax** shows minimum and maximum vario value in last average time (by default 20s)
- **G-meter** shows minimum and maximum G-force in last flight

5.3.8 Communication

Use to configure **baudrate** for **GPS** and **PDA port**.

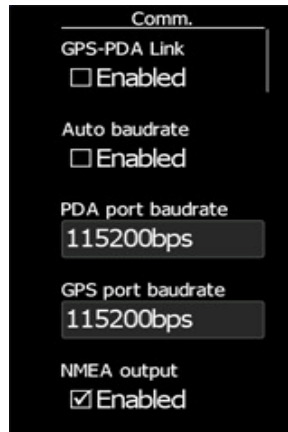

Each port can be configured separately. If your PDA device does not support automatic switch to DIRECT LINK between GPS and PDA port, here is manual **GPS-PDA link** menu. When **autobaudrate** is enabled, LXNAV V7 will automatically search on all speeds to receive valid data. When receives a valid NMEA sentence it will lock on that baudrate and stop searching. In case that communication is lost LXNAV V7 will start again searching on all baudrates. All GPS and FLARM data received on GPS port will be forwarded to PDA port.



Baudrate on PDA must not be lower than the setting on GPS port



To get better performance of LXNAV V7 it is recommended that both baudrates be set as high as possible.

NMEA output on PDA port can be enabled or disabled. If you are not using a PDA port, this setting should be disabled.

5.3.8.1 Bluetooth on PDA port

From version 2.02, V7 supports plug and play LXNAV V7 BT module. Module can be plugged in PDA port.



In case, that we want to use this module, we must select under PDA baudrate **LXV7 Bluetooth**. If Bluetooth will be detected, on main screen will be displayed BT icon.

In case of synchronization error, an error message will appear.

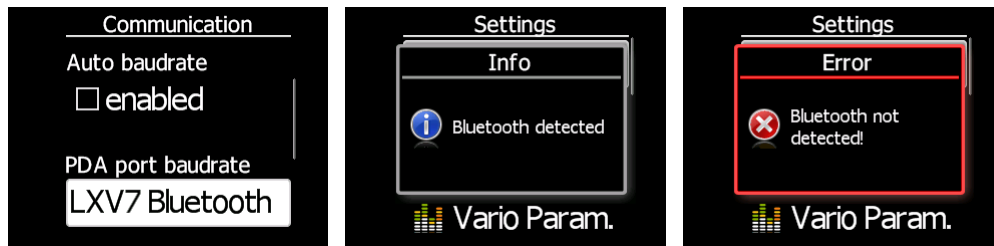

At power up of V7 same messages will be present.



On PDA side is necessary to pair Bluetooth with LXNAV V7 Bluetooth module. Pairing is completed, when is entered pairing code „1234“.

5.3.9 Polar and Glider

Use this dialogue to enter glider polar and other glider properties. As a default polar a standard class glider is enabled automatically .



The image shows a configuration dialog box for a glider. It has a title bar 'Glider type' and a list of input fields, each with a label and a value:

Field Label	Value
Glider type	JS-1
Class	18-meter
Stall speed	78 ^{km/h}
A	1.42
B	-2.62
C	1.73
Minimum load	37.5 ^{kg/m²}
Min. glider weight	390 ^{kg}
Max. glider weight	600 ^{kg}
Empty glider weight	320 ^{kg}
Pilot weight	80 ^{kg}
Copilot weight	0 ^{kg}

Polars for most modern gliders are already prepared. Use Glider type control, to list between preloaded glider polars.

All glider data will be copied from the chosen polar. To check the best glide ratio and minimum sink rate, to see if the polar data matches the glider performance, you may look in MacCready setting menu. You can modify the polar by changing coefficients **a**, **b** and **c**. A polar is defined as a quadratic equation with the parameters a, b, and c. Use the SeeYou program (Tools->Polar) to calculate coefficients a, b and c for a given glider's polar. The program requires three sink points entered at selected speeds (e.g.: 100 km/h, 130 km/h, and 150 km/h). The program will calculate the values of a, b and c, which should be noted and entered into the LXNAV V7.

Stall speed is used to generate stall warnings which are available only with integrated Voice module (Not integrated in LXNAV V7).

Weights must be entered and user should enter ballast in kilograms. There are three weights to enter. **Min. Weight** (*Minimum glider weight*) corresponds to the min.load value and represents the value at which the polar was measured or recalculated. **Max. weight** (*Maximum glider weight*) is the maximum take-off weight allowed for a glider. It is not used in the calculation, it is just a reminder to the pilot of the maximum take-off weight. **Empty weight** (*Empty glider weight*) is weight of the glider without pilot and ballast. The overload factor is calculated as:

$$\text{overload} = \frac{\text{Empty.glider.weight} + \text{Pilot.weight} + \text{Water.ballast}}{\text{Minimum.glider.weight}}$$

Empty glider weight is a weight of empty glider. This number can be found in a glider book.

Pilot weight is weight of the pilot with parachute and baggage.

Water ballast is a weight of ballast.

Minimum glider weight is a *weight of empty glider + minimum pilot weight*. This value is useful for when we want to display ballast in weight (kg or lbs).

Maximum glider weight is MTOW (*max. takeoff weight*) – this value is used only to limit pilot to enter higher ballast, as is allowed with MTOW.

5.3.10 Flarm

By enabling the item, **show flarm warning**, Flarm warnings will be shown on the main screen.



Each warning can be dismissed with push button. **Dismiss time** is time period during which the instrument will not give you any warning after pressing dismiss. In the event that **dismiss while circling** is enabled, the dismiss period will be extended until end of circling flight is detected.

5.3.11 Password

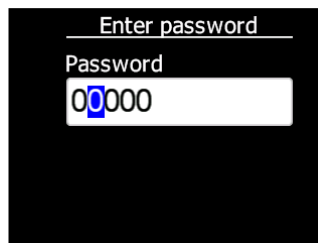

There are several passwords which run specific procedures as listed below:

- **00666** Resets all settings to factory default
- **99999** will clean logbook
- **01048** can adjust needle on zero. (necessary only after update to version 2.0)
- **01049** can align airspeed on zero.



Do not adjust needle, or autozero when airborne.

5.3.12 Reset of accelerometer (g-meter)

Accelerometer can any time be reset manually. After take off it is reset automatically.



5.3.13 About

In about page is information about firmware versions, hardware versions and serial numbers.



6 Variometer and Altimeter

All signals from the pneumatic sensors (altitude, speed) are derived from high quality pressure sensors which mean that no flask is necessary. The vario signal is derived from the altitude signal. All signals are temperature and altitude compensated. Mechanical needle and colour display show the vario information as well as many other parameters.

The display is user configurable. The variometer can be configured to show:

- **Range** 5, 10 and 2.5 m/s or 10, 20 and 5 kts.
- **time constants** 0.1 s to 5 s, in addition there are 4 settings for electronic processing for the vario signal.
- **netto** shows the air mass lift and sink.
- **relative** shows the lift or sink that would be achieved if the glider was circling at the thermaling speed.

There are two ways by which the vario indications can be corrected for total energy. Electronic TE compensation based on speed changes with time and pneumatic compensation with a TE probe. The quality of the TE compensation depends entirely on the location, size and dimension of the TE tube. The installation must be leak-proof.



If an electronic TE compensation is selected the TE (P_{st}) port should be connected to a good static pressure source. If pneumatic compensation is selected the TE (P_{st}) port should be connected to the TE probe.

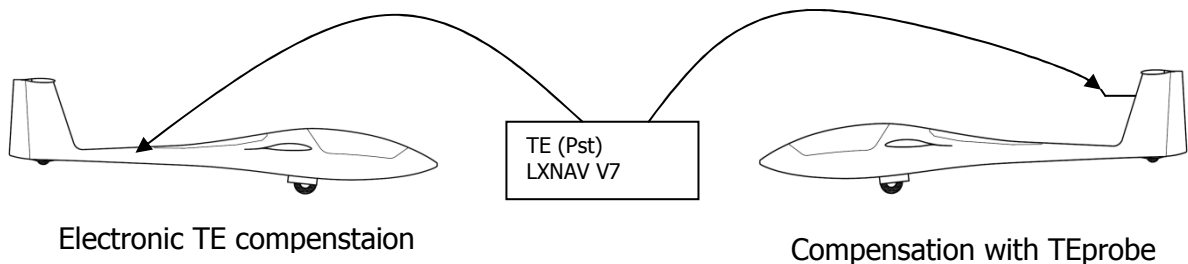

Altimeter

The altimeter of the LXNAV V7 is temperature compensated from -20°C up to $+60^{\circ}\text{C}$. The altimeter is calibrated up to 20000 m.

6.1 Speed Command

Speed command flying based on the MacCready theory is a very useful tool to optimise cross-country speed. There are many visual indicators (see Chapter 5.1). When the instrument changes to speed command mode the audio will change and become a director informing the pilot whether he is flying too fast or too slow. In order to reduce confusion between vario and speed command audio some special features are incorporated

- Continuous audio signal in + possible (other kinds of signals can be chosen, see setup).
- No audio at correct speed (dead band).

7 Flying with the LXNAV V7

To get the best out of the LXNAV V7 it is important that some preparation is done prior to take-off. Trying to configure the instrument or set a task while flying is very hazardous especially in a competition. At the least, it could spoil your whole day! Pre-flight preparation will ensure that the flight will be both safe and enjoyable.

7.1 On the Ground

7.1.1 Power on Procedure

Press the push button. LXNAV V7 welcome screen will appear. The first screen shows the version of the boot loader, firmware, hardware and serial number. The boot procedure normally takes few seconds. When completed, Set Elevation dialogue is shown.

7.1.2 Set Elevation and QNH

This setting is crucial for final glide calculation: therefore pay careful attention to it.

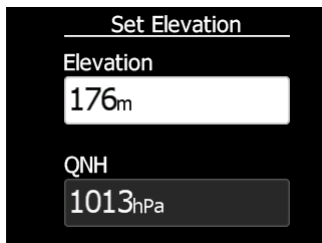

The instrument will offer elevation over standard pressure level QNE. Use the knob to fine-tune the elevation.

The **QNH** should be changed only when airfield elevation and QNH pressure are given. This might happen on some competitions.

In all other cases elevation should always match QNH pressure.



The Set Elevation dialogues are not shown if the LXNAV V7 is switched off and on during flying. Dialogue will also quit after 15 seconds if pilot does not do anything.

7.1.3 Pre-flight Check

After elevation setup the LXNAV V7 will switch to normal operation mode.

It is recommended that the MacCready, ballast and bugs settings be set to match the current glider configuration. Press the **push** button. The dialogue for MacCready, Ballast and Bugs will appear.

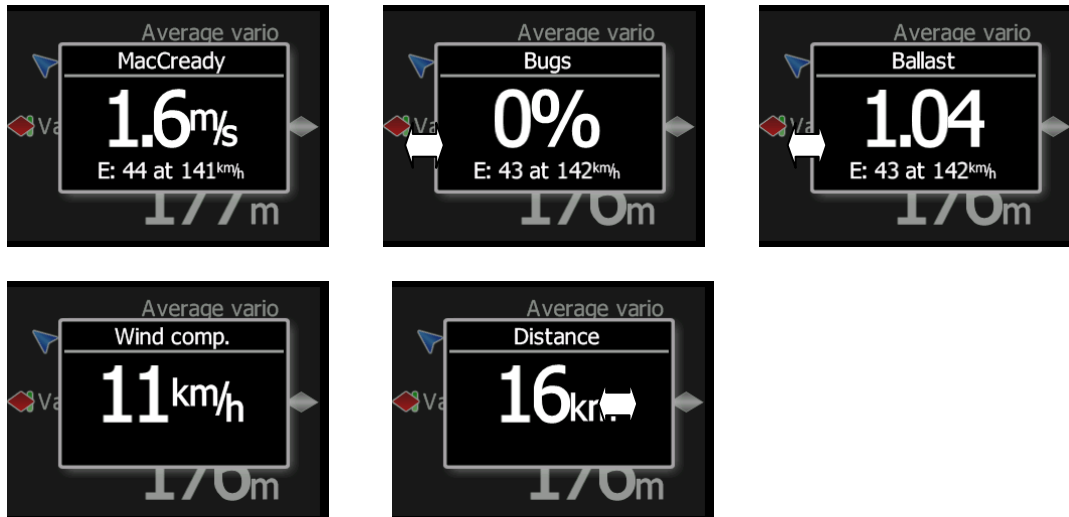

Use the rotary knob to modify the MacCready setting. Refer to Chapter 5.2 for more details. It is also highly recommended to check the safety altitude setting. Refer to Chapter 5.3.3 to find out how to define the safety altitude.

7.2 Airborne

7.2.1 Final glide calculation

Final glide is a function calculated from distance, target elevation, altitude, wind component, MC setting and Bug setting. If V7 get enough data, everything is done automatically (GPS and PDA provides all necessary information – position, target elevation). If such data is not available, pilot must manually enter missing data, that V7 will calculate final glide.

8 Installation

The LXNAV V7 requires a standard 57 mm cut-out.

Three pressure connectors are fitted to the back of the V7. A label shows their functions.

- P_{static} means static pressure connector.
- P_{total} means pitot or total pressure connector.
- TE means total energy TE pressure connector.

If the unit is to be configured for electronic TE compensation the connections are as follows:

- P_{static} Static
- P_{total} Pitot or Total pressure
- TE/ P_{static} Static

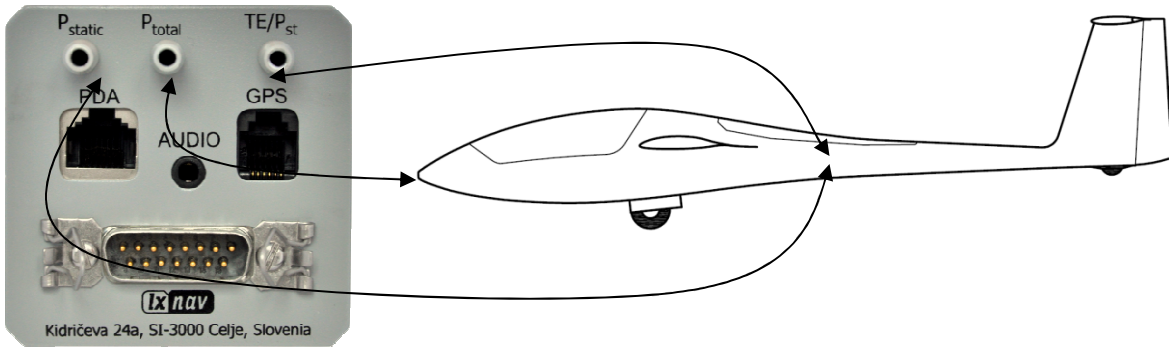

If the unit is to be configured for pneumatic TE compensation using a TE tube, then the connections are:

- TE/ P_{static} TE tube
- P_{static} Static
- P_{total} Pitot or Total pressure

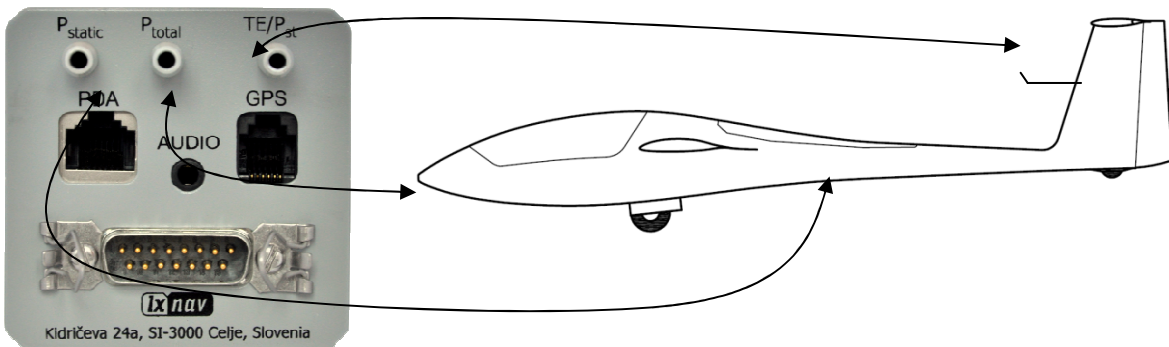

If the P_{total} and Static are connected the wrong way around there will be no integrator (average climb) and speed to fly indication during the flight.

The LXNAV V7 is connected to 12 Volt power via the 15-pin SUB-D connector. Optionally LXNAV V7D can be connected via the CAN bus and the connectors are labelled with "**CAN**" at each end.



Instrument has no internal fuse. **3A external fuse is required!** Power supply cables should use a minimum of 0.5 mm² wires.

8.1 Installing the LXNAV V7

The LXNAV V7 vario should be mounted in a standard 57 mm hole.

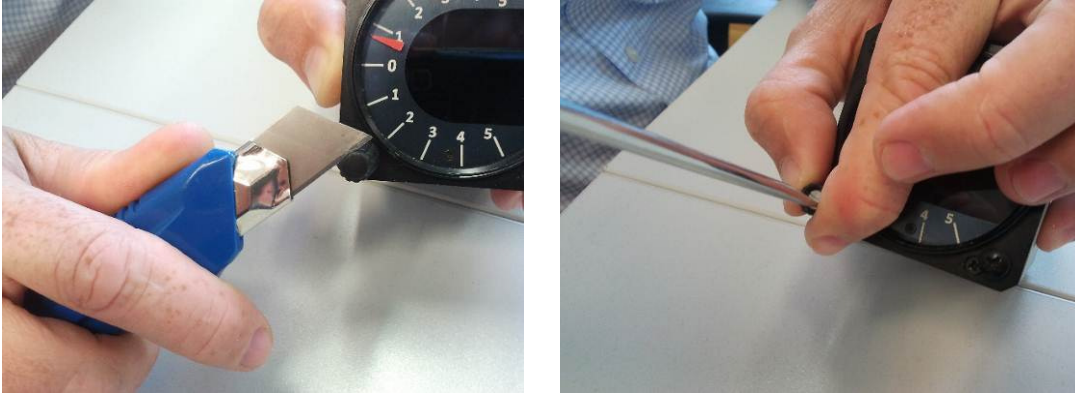

Remove rotary knob cap with a knife or flat screw driver, then hold knob and unscrew it. Remove remaining three screws. Install V7 into the panel, screw back all screws and knob. Make sure that between knob and panel is some space, to push button.



Be sure that LXNAV V7 is placed far enough from compass. Inside is stepper motor which generates magnetic field interferences.

8.2 Connecting LXNAV V7

LXNAV V7 is connected to 12V DC power supply. Red wire goes to + positive and blue wire goes to – ground. If you don't use V7D (second seat unit). Can connector should be left terminated with CAN terminator. SC cable is used for external switch, for switching between climb and cruise mode.

8.3 Cutout of V7

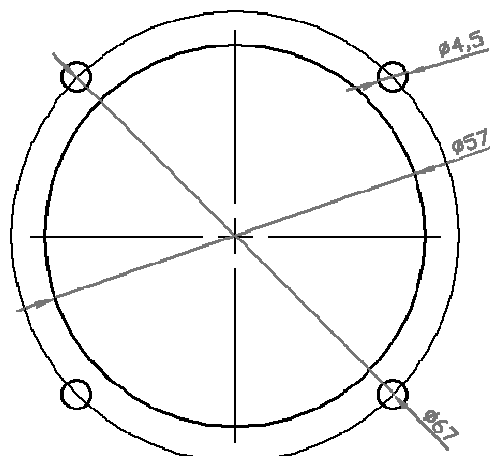

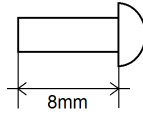

Length of screw is limited to max 6mm!

8.4 Installation of options

To the LXNAV V7 can be optionally connected 2nd seat repeater unit LXNAV V7D.

8.4.1 Ports and Wiring

8.4.1.1 LXNAV V7 ports

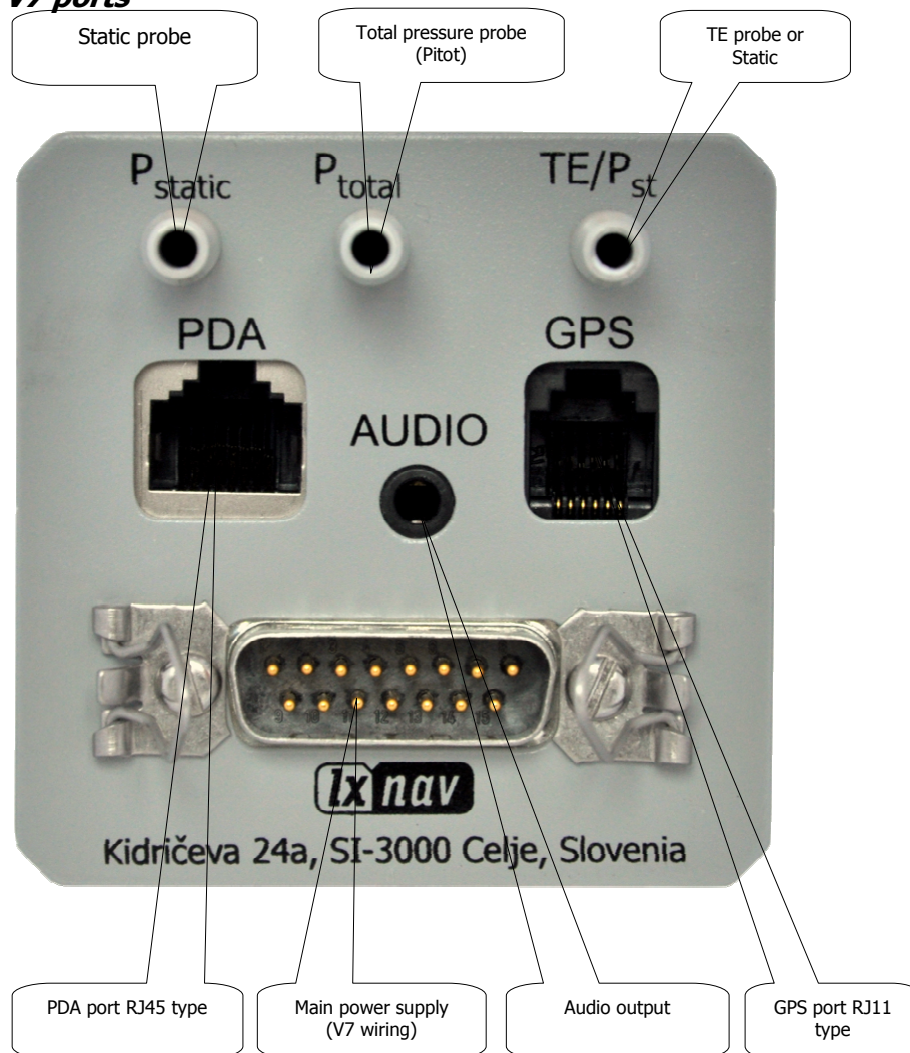

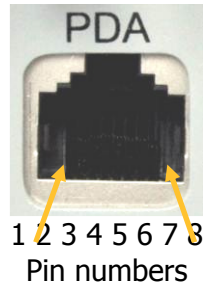
PDA port (RJ45)

Pin number	Description
1,2	Ground
3	(output) Transmit from LXNAV V7 RS232 (e.g. Computer, IPAQ38/39xx)
4	(input) Receive to LXNAV V7 RS232 (e.g. Computer, IPAQ38/39xx)
5	(output) Transmit from LXNAV V7 LV-TTL (3.3V) (e.g. Oudie, HP302, HP31x)
6	(input) Receive to LXNAV V7 LV-TTL (3.3V) (e.g. Oudie, HP302, HP31x)
7,8	5V OUTPUT (maximum 1A)



RJ45 plug is NOT designed in accordance with IGC standard. It can be used only with dedicated cable. Do not plug unknown cable to it as it may damage LXNAV V7 unit.

GPS port (RJ11)

Pin number	Description
1	(output) 12V DC, to supply GPS
2,3	N.C.
4	(input) Receive to LXNAV V7 RS232 (e.g.NANO power 232)
5	(output) Transmit from LXNAV V7 RS232 (e.g.NANO power 232)
6	Ground

Main port

On main port is connected V7 wiring.

Audio port

Here is connected speaker with standard 3mm phono jack.



This port is designed to be connected 8 ohm speaker supplied with V7. Please consult with your dealer, if you want to make different connection.

8.4.1.2 LXNAV V7 wiring

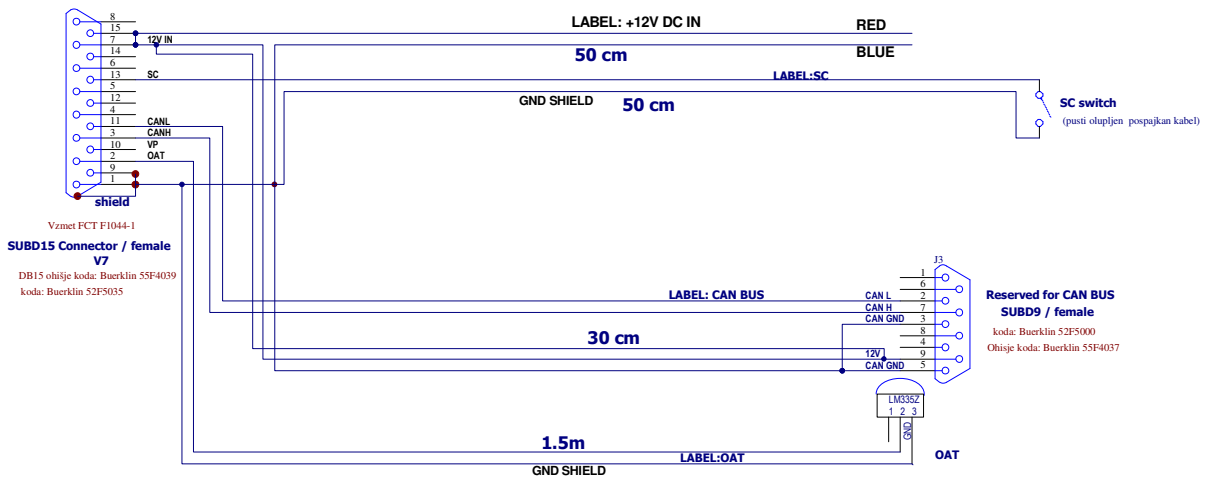

If CAN BUS cable is not connected to LXNAV V7D, CAN connector must be terminated with CAN TERMINATOR!

8.4.2 Configurations

8.4.2.1 NANO – V7 – OUDIE

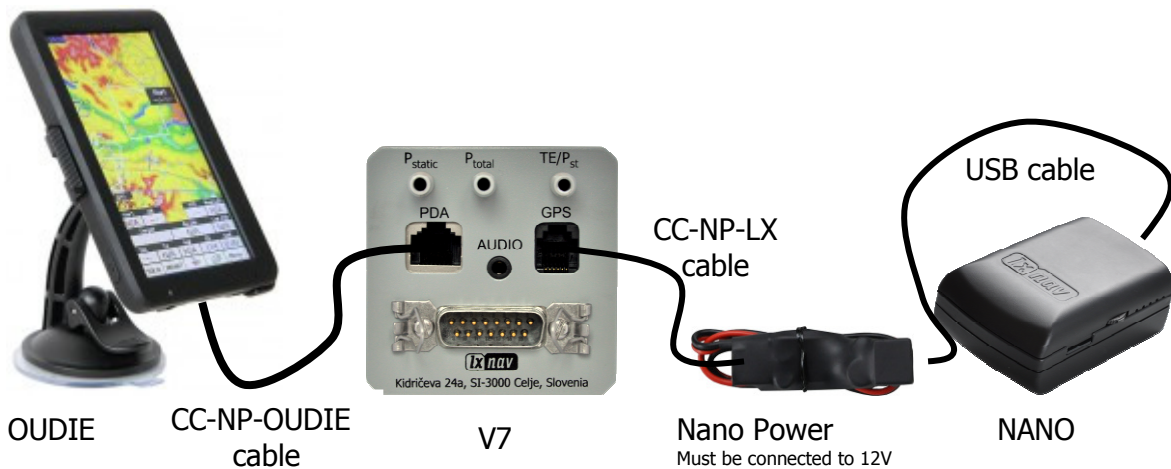

8.4.2.2 NANO3 – V7 – MINIMAP

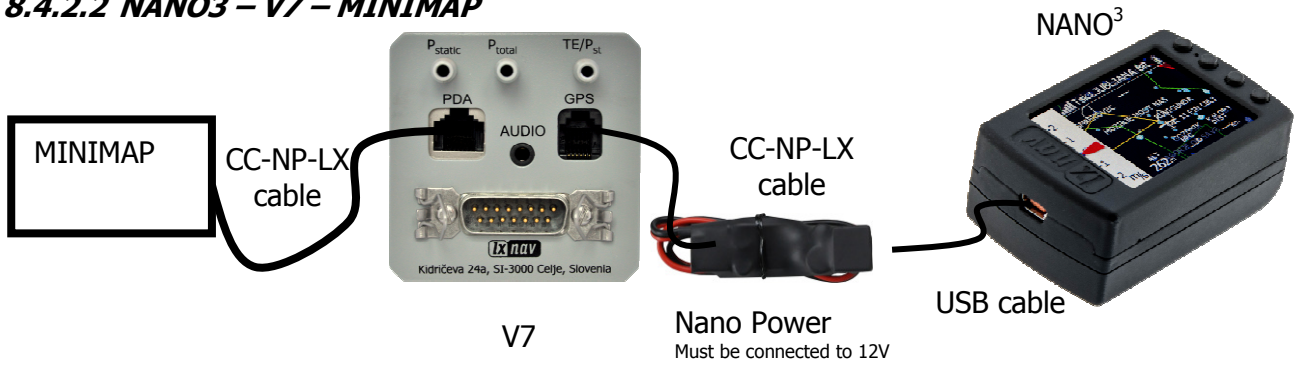

8.4.2.3 COLIBRI2 – V7 – OUDIE

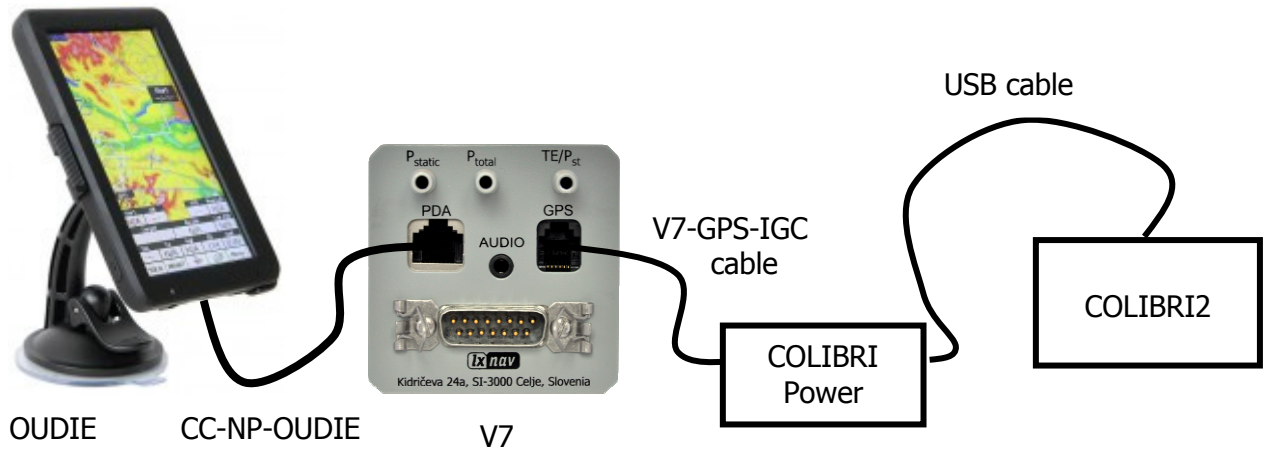

8.4.2.4 COLIBRI, VOLKSLOGGER – V7 – OUDIE

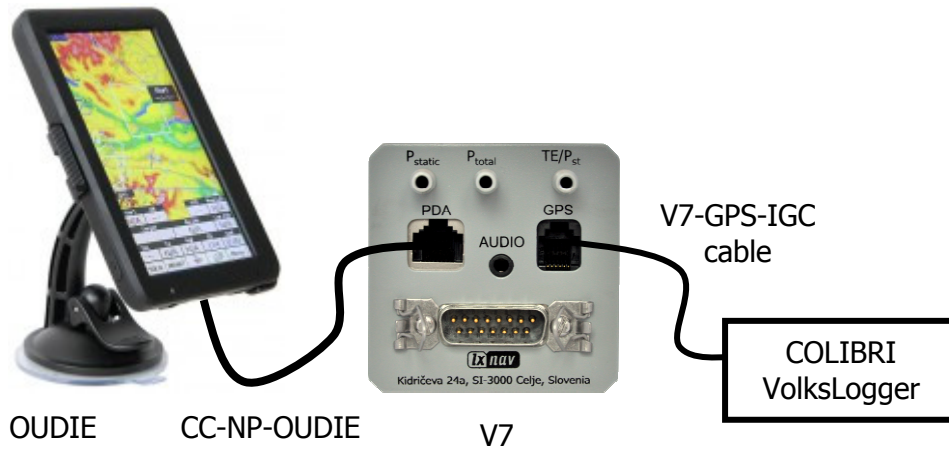

8.4.2.5 Flarm/RedBox – V7 – OUDIE

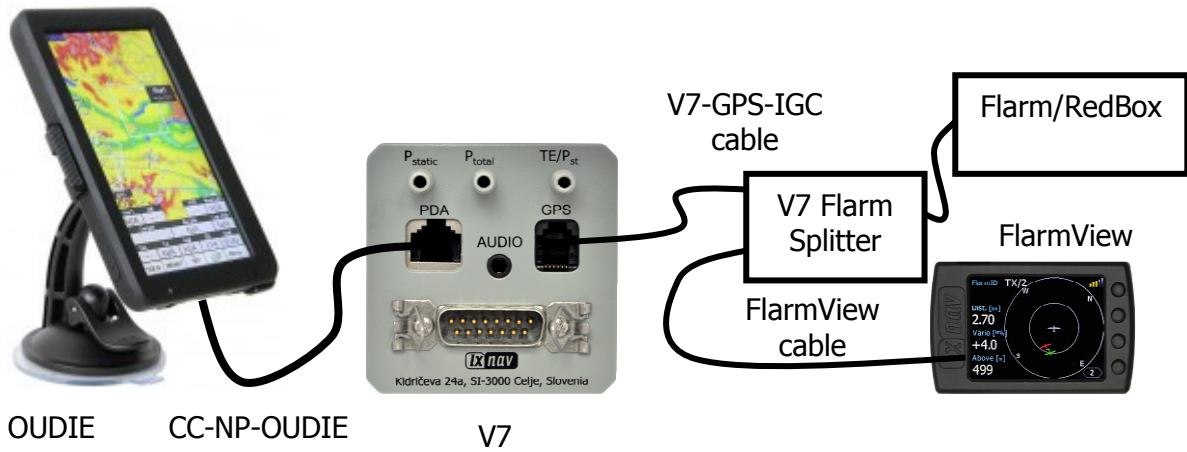

8.4.2.6 FlarmMouse - FlarmView -V7 - OUDIE

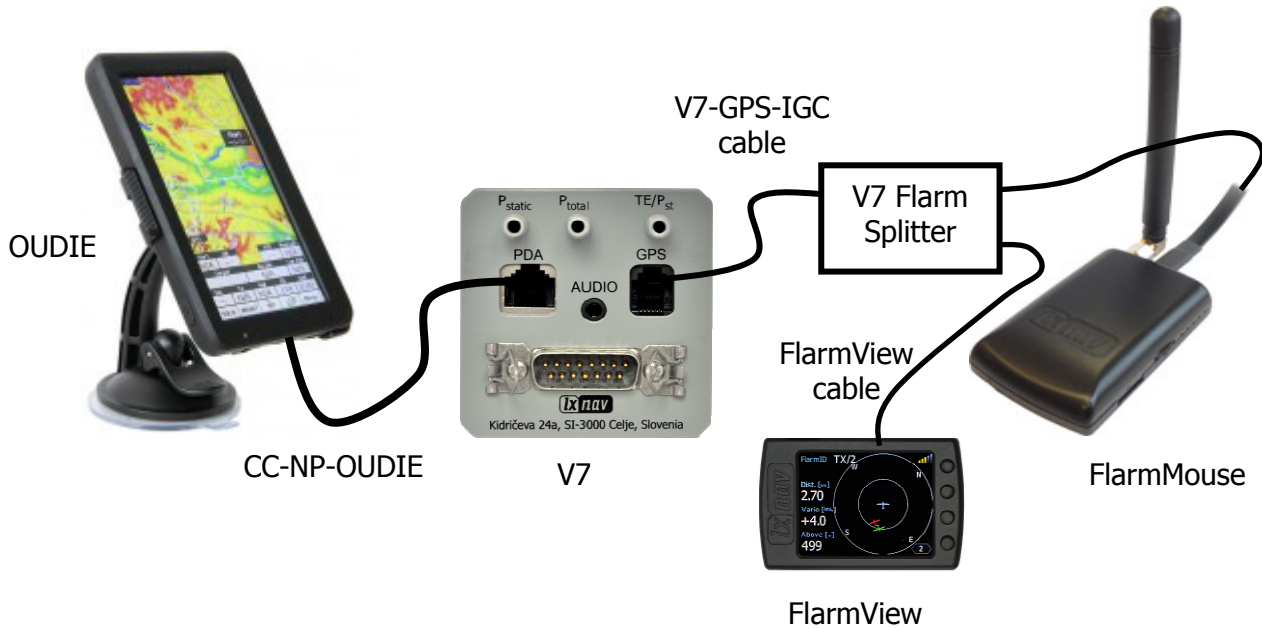

8.4.2.7 FlarmMouse – V7 – OUDIE

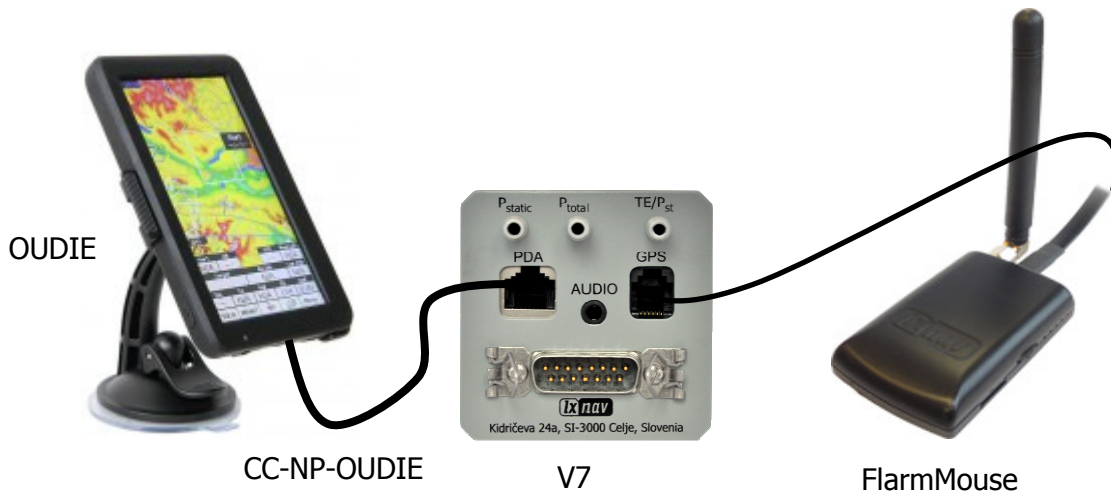

8.4.3 V7D option (V7 repeater)

One or more V7D repeaters can be connected together via the CAN bus. With a double seater configuration, the user can equally control and configure the V7 vario from both seats.



9 Firmware Update

Firmware updates of the LXNAV V7 can be easily carried out using PDA or PC. Please visit our webpage www.lxnav.com and check for the updates.

You can also subscribe to a newsletter to receive news about the LXNAV V7 automatically.

9.1 Updating LXNAV V7 firmware using OUDIE

Firmware update can be done with OUDIE version **4.20** or higher. You need CC-NP-OUDIE1 cable.



Be sure that PDA baudrate on V7 is set to 115200bps.

The procedure is following:

1. Download the latest firmware from <http://www.lxnav.com/download/firmware.html> and update tool. Firmware consist of two files **App_VINB_x.yy.lxfw** and **App_VSEV_x.yy.lxfw**.
2. Copy them to SD card (Oudie)
3. Go into Setup-Settings-LXNAV V7(2)
4. Click button "update firmware"
5. Choose application LXNUpdate.exe (if SeeYou did not find that file, you must download it from our web site <http://www.lxnav.com/download/firmware.html>)
Firmware files must be in same folder as LXNupdate.exe. LXNupdate will not work if in same folder is not copied also **CelxV.dll**.
6. Seeyou will close and firmware app will run
7. Choose firmware file **App_VINB_x.yy.lxfw**, correct Comm. Port and speed (115200bps)
8. Press "update" button
9. Firmware will be updated by following sequence (Loading firmware, Discovering, synchronizing, programming)
10. Exit the Program Power Down the V7 and restart the V7
11. Please repeat procedure for 2nd firmware file **App_VSEV_x.yy.lxfw** from step 7.

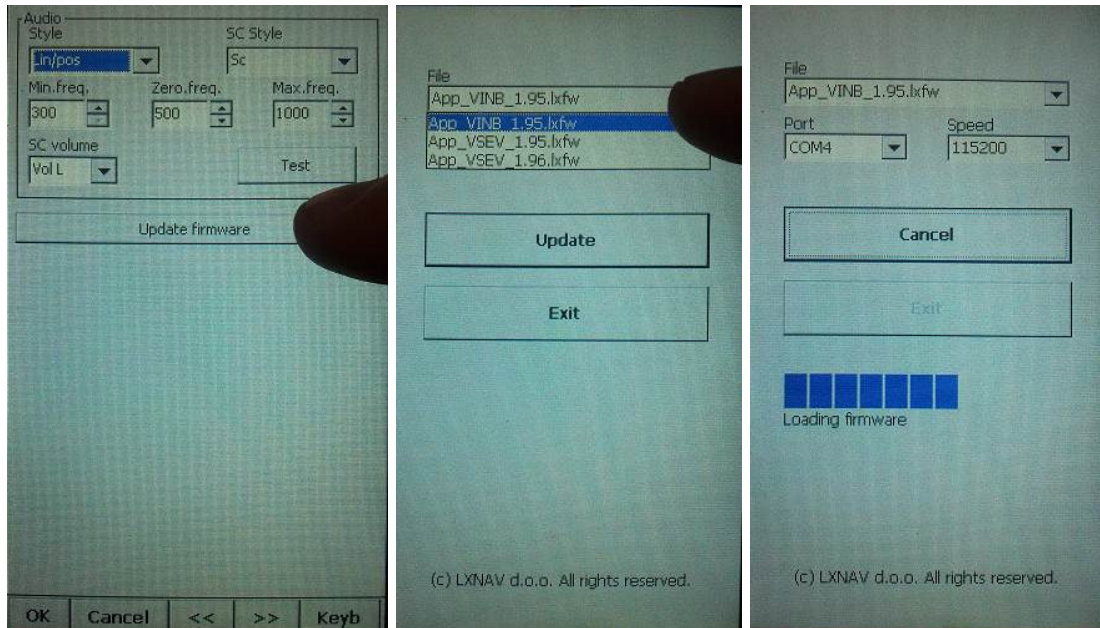

See tutorial on: <http://youtu.be/bRrgHpKpzPU>

9.2 Updating LXNAV V7 firmware using PC

Update procedure of V7 using PC is similar to procedure on OUDIE. You need CC-NP-232 cable and free serial port on your PC. If your PC has no serial ports, you can use USB to SERIAL converter.



Be sure that PDA baudrate on V7 is set to 115200bps.

1. Download the latest firmware and update tool from our web site, section downloads/firmware <http://www.lxnav.com/download/firmware.html>. Firmware is compressed in a zip file. It consist of two files **App_VINB_x.yy.lx_fw** and **App_VSEV_x.yy.lx_fw**.
2. Unpack file to one folder and run FlashLoader485App.exe (PC update tool)
3. Choose firmware file **App_VINB_x.yy.lx_fw**

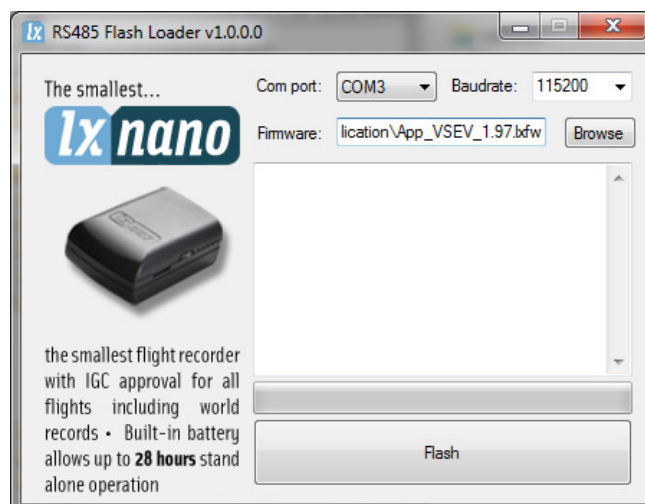

4. Choose correct **serial port** and baud rate (**115200bps**)
5. Press "**Flash**" Button. If update starts, you will see a progress on PC and on V7.

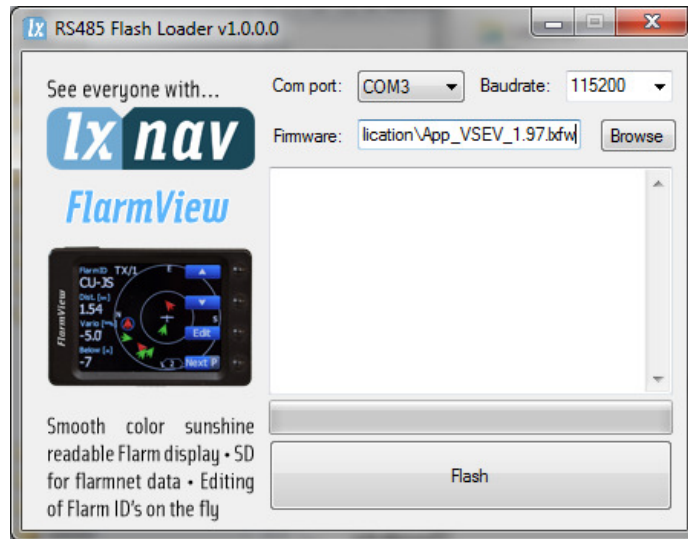

6. Now you can choose second file **App_VSEV_x.yy.lxfw** and repeat procedure from step 3.

Update od »VINB« firmware takes little longer as »VSEV«.



If update procedure is interrupted of any case. LXNAV V7 will not start. It will cycle in bootloader application with red message "Flash integrity failed". Bootloader application is waiting to receive new firmware from OUDIE or PC over PDA port. After successful firmware update LXNAV V7 will start again.



If V7 gives you message "Flash integrity failed", means that firmware update was not successful and need to be repeated. If the menus are still working behind the message screen, you must repeat update with "**App_VSEV_x.yy.lxfw**" file otherwise you must repeat update with "**App_VINB_x.yy.lxfw**" file.

10 Options

10.1 Rear Seat Device (LXNAV V7D)

In two-seat gliders it is possible to install the LXNAV V7D rear seat device. The V7D looks almost identical to the V7. In fact it runs on exactly the same software as on first seat device.

The basic idea of two-seat configuration is that both devices work independently from each other with the possibility of automatically exchanging various pieces of data (Loudness, Mc, polar...).

10.1.1 Data Exchange

All data is exchanged between front and rear unit. LXNAV V7 also exchanges data with GPS and PDA. Change of MC, Bal, Bugs, Volume, polar settings,... on PDA, will have also influence on LXNAV V7. Same will happen also in opposite way.

10.1.2 Cable Wiring (LXNAV V7D)

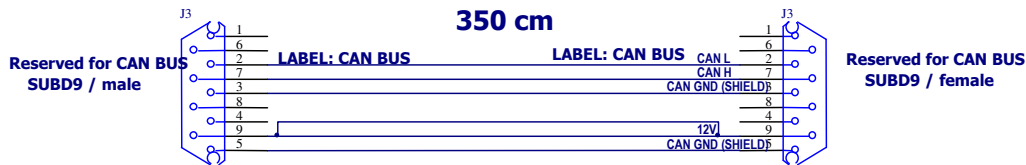

10.2 Available cables for GPS and PDA ports

GPS port

Device	Cable code
Nano power	CC-NP-LX <i>(RX/TX are crossed)</i>
Generic RS232 with female DB9	V7-GPS-232
Flight recorders, FLARMS with standard 6p IGC connector RJ11 type, Red Box, Colibri, Colibri2, VL	V7-GPS-IGC
Power flarm (RJ45), K6 mux	V7-GPS-PF
Power flarm Core	V7-GPS-PFCORE

PDA port

Device	Cable code
OU DIE	CC-NP-OU DIE1
Generic RS232 with female DB9	CC-NP-232
IPAQ 310/314	CC-NP-IPAQ310
IPAQ 38/39xx/47xx	CC-NP-38
MiniMap	CC-NP-LX
Butterfly Connect	CC-NP-BFC



PDA and GPS are not designed in accordance with IGC standard. It can be used only with dedicated cable. Do not plug unknown cable to it as it may damage LXNAV V7 unit.

11 Revision History

November 2011	Initial release of owner manual
January 2012	New chapters Ch.8.4.2, Ch.8.2
March 2012	New release of version 1.97, mod. Ch. 5.3.8
March 2012	New release of version 1.98, mod. Ch. 5.3.8 (removed altitude source)
June 2012	New release of version 2.00, mod. Ch.2, Ch.4.3, Ch 5.3.11
August 2012	New release of version 2.02, New Ch.5.3.8.1, Mod Ch.5.1, Ch.5.1.1
October 2012	Swapped chapters 10.1.2 and 10.2, Updated 5.3.8.1
November 2012	Added chapter 8.4.2 (Configurations)
February 2013	SC tab renamed to Dead Band Ch.5.3.4.9
September 2013	New release of version 3.00 New/updated chapters Ch.5.3.1, 5.3.4.4, 5.3.4.5, 5.3.4.6, 5.3.4.10, 5.3.4.13, 5.3.4.14, 0, 0, 0, 5.3.3, 5.3.4, 5.3.5, 5.3.6, 5.3.8, 5.3.9, 5.3.10
October 2013	New release 3.01 Updated chapter 5.3.1, new chapter 7.2.1
December 2013	New chapter 5.3.4.1