

F L I G H T M A N U A L

for

Sailplane

Model : Ventur 2c

Serial-No. : 4 2

Registr.-No. :

Date of Issue : November 1995

Pages as indicated by "LBA-app." are approved
by



Signature

LUFTFAHRT BUNDESAMT

Authority



Stamp

26. Sep. 96

Original date
of approval

This sailplane is to be operated in compliance
with information and limitations contained
herein.

Approval of translation has been done by best knowledge and judgement.

0.1 Erfassung der Berichtigungen / Records of revisions

Lfd. Nr. der Berichtigung	Abschnitt	Seiten	Datum der Berichtigung	Bezug	Datum der Anerkennung durch das LBA	Datum der Einarbeitung	Zeichen / Unterschrift
Revision No.	Affected section	Affected page	Date of issue	Reference	Date of Approval by LBA	Date of Insertion	Signature
1	0 6	0.2.7 6.2.5 6.2.7	Febr. 1996	ÄB 349-28 Werk-Nr. 1 bis 7 MB 349-28 S/N 1 through 7			
2	0 1	0.2.2 1.4.1	Juni / June 1997	TM 349-22 hydr. Radbremse wahlw. alle Werknr. TN 349-22 <i>hydr. wheel brake optional all S/N</i>			
3	0 1 2 3 4 5 6	0.2.2 0.2.3 0.2.4 0.2.5 0.2.6 0.2.7 1.4.3 2.6 2.15 3.5 4.5.3.1 4.5.3.2 4.5.3.3 5.2.2 6.2.5	Sept. 1997	TM 349-21 Erhöhung der max. Flugmasse bei 18m Spannwr. Werk-Nr. 8 bis 30 wahlweise ab Werk-Nr. 31 serienmäßig TN 349-21 <i>Increase of the max. all up mass for 18m wing span</i> <i>S/N 8 – 30 optional standard on S/N 31 and on</i>			
4	0 4	0.2.5 4.5.3.3 4.5.4.1 4.5.4.2	Dez. / Dec. 1997	TM 349-23 Ergänzungen Werk-Nr. 1 bis 32 ab Werk-Nr. 33 serienmäßig TN 349-23 <i>Supplements</i> <i>S/N 1 through 33 standard on S/N 33 and on</i>			

MB: Modification Bulletin – Änderungsblatt
TN : Technical Note – Technische Mitteilung

0.1 Erfassung der Berichtigungen / Records of revisions

Lfd. Nr. der Berichtigung	Ab-schnitt	Seiten	Datum der Berichtigung	Bezug	Datum der Anerkennung durch das LBA	Datum der Ein-arbeitung	Zeichen /Unter-schrift
Revision No.	Affected section	Affected page	Date of issue	Reference	Date of Approval by LBA	Date of Insertion	Signature
5	0 7	0.2.1 0.2.8 7.2.6	April 2000	<u>ÄB 349-35</u> Werk-Nr. 32 und ab Werk-Nr. 63 serienmäßig <u>MB 349-35</u> <i>S/N 32 and 63 and on</i>			
6	0 7	0.2.8 7.2.1 7.2.2	Juni / June 2000	<u>ÄB 349-36</u> Lüftung Werk-Nr. 1 bis 62 wahlw. ab Werk-Nr. 63 serienm. <u>MB 349-36</u> <i>Ventilation S/N 1 – 62 optional standard on S/N 63 and on</i>			
7	0 4	0.2.5 4.5.6.1 4.5.6.4	Juni / June 2000	<u>ÄB 349-37</u> ab Werk-Nr. 61 serienm. <u>MB 349-37</u> <i>standard on SN 61 and on</i>			
8	0 9	0.2.10 9.2 9.3.1 9.3.2 9.3.3 9.3.4 9.3.5	Okt. / Oct. 2006	<u>TM-Nr. 349-31</u> Einbau einer Notaus- stiegshilfe wahlweise alle Werk-Nr. <u>TN-No. 349-31</u> <i>Installation of an emergency bail out assistance system optional all serial numbers</i>			

MB: Modification Bulletin – Änderungsblatt
TN : Technical Note – Technische Mitteilung

0.1 Record of revisions

Any revisions of the present manual, except actual weighing data, must be recorded in the following table and in the case of approved sections be endorsed by the responsible airworthiness authority.

The new or amended text in the revised page will be indicated by a black vertical line in the left hand margin, and the revision number and the date will be shown on the bottom left hand side of the page.

0.2 Verzeichnis der Seiten / List of effective pages

Ab-schnitt	Seite	Ausgabe-datum	Bezug	
0	0.1.1			
	0.1.2			
	0.1.3			

0.2 Verzeichnis der Seiten / List of effective pages

Ab-schnitt	Seite	Ausgabe-datum	Bezug
1	1.1.1	Nov. 1995	
	1.1.2	Nov. 1995	
	1.2	Nov. 1995	
	1.3	Nov. 1995	
	1.4.1	Juni 1997	TN 349-22
	1.4.2	Nov. 1995	
	1.4.3	Sept.1997	TN 349-21
	1.5	Nov. 1995	

0.2 Verzeichnis der Seiten / List of effective pages

Ab-schnitt	Seite	Ausgabe-datum	Bezug
2	2.1.1	Nov. 1995	
	2.1.2	Nov. 1995	
	LBA-ank. 2.2	Nov. 1995	
	LBA-ank. 2.3	Nov. 1995	
	LBA-ank. 2.4	Nov. 1995	
	LBA-ank. 2.5	Nov. 1995	
	LBA-ank. 2.6	Sept.1997	TN 349-21
	LBA-ank. 2.7	Nov. 1995	
	LBA-ank. 2.8	Nov. 1995	
	LBA-ank. 2.9	Nov. 1995	
	LBA-ank. 2.10	Nov. 1995	
	LBA-ank. 2.11	Nov. 1995	
	LBA-ank. 2.12	Nov. 1995	
	LBA-ank. 2.13	Nov. 1995	
	LBA-ank. 2.14	Nov. 1995	
LBA-ank. 2.15	Sept.1997	TN 349-21	

0.2 Verzeichnis der Seiten / List of effective pages

Ab- schnitt	Seite	Ausgabe- datum	Bezug
3	3.1.1	Nov. 1995	TN 349-21
	3.1.2	Nov. 1995	
	LBA-ank. 3.2	Nov. 1995	
	LBA-ank. 3.3	Nov. 1995	
	LBA-ank. 3.4	Nov. 1995	
	LBA-ank. 3.5	Sept.1997	
	LBA-ank. 3.6	Nov. 1995	
	LBA-ank. 3.7	Nov. 1995	
	LBA-ank. 3.8	Nov. 1995	
	LBA-ank. 3.9.1	Nov. 1995	
	LBA-ank. 3.9.2	Nov. 1995	

O.2 Verzeichnis der Seiten / List of effective pages

Ab-schnitt	Seite	Ausgabe-datum	Bezug
4	4.1.1	Nov. 1995	
	4.1.2	Nov. 1995	
	LBA-ank. 4.2.1	Nov. 1995	
	LBA-ank. 4.2.2	Nov. 1995	
	LBA-ank. 4.2.3	Nov. 1995	
	LBA-ank. 4.3.1	Nov. 1995	
	LBA-ank. 4.3.2	Nov. 1995	
	LBA-ank. 4.3.3	Nov. 1995	
	LBA-ank. 4.3.4	Nov. 1995	
	LBA-ank. 4.4	Nov. 1995	
	LBA-ank. 4.5.1.1	Nov. 1995	
	LBA-ank. 4.5.1.2	Nov. 1995	
	LBA-ank. 4.5.1.3	Nov. 1995	
	LBA-ank. 4.5.1.4	Nov. 1995	
	LBA-ank. 4.5.2	Nov. 1995	
	LBA-ank. 4.5.3.1	Sept. 1997	TN 349-21
	LBA-ank. 4.5.3.2	Sept. 1997	TN 349-21
	LBA-ank. 4.5.3.3	Dez. 1997	TN 349-21 TN 349-23
	LBA-ank. 4.5.3.4	Nov. 1995	
	LBA-ank. 4.5.3.5	Nov. 1995	
	LBA-ank. 4.5.4.1	Dez. 1997	TN 349-23
	LBA-ank. 4.5.4.2	Dez. 1997	TN 349-23
	LBA-ank. 4.5.5	Nov. 1995	
	LBA-ank. 4.5.6.1	Nov. 1995	
	LBA-ank. 4.5.6.2	Nov. 1995	
	LBA-ank. 4.5.6.3	Nov. 1995	
	LBA-ank. 4.5.6.4	Nov. 1995	
	LBA-ank. 4.5.6.5	Nov. 1995	
	LBA-ank. 4.5.7.1	Nov. 1995	
	LBA-ank. 4.5.7.2	Nov. 1995	
	LBA-ank. 4.5.8	Nov. 1995	
	LBA-ank. 4.5.9	Nov. 1995	

0.2 Verzeichnis der Seiten / List of effective pages

Abschnitt Affected section	Seite Affected pages	Ausgabe-Datum Date of issue	Bezug Reference
5	5.1.1 5.1.2 LBA-ank. 5.2.1 LBA-ank. 5.2.2 LBA-ank. 5.2.3 LBA-ank. 5.2.4 5.3.1 5.3.2.1 5.3.2.2	Nov. 1995 Nov. 1995 Nov. 1995 August 2003 Nov. 1995 Nov. 1995 Nov. 1995 Nov. 1995 Nov. 1995	TN 349-21

0.2 Verzeichnis der Seiten / List of effective pages

Ab-schnitt	Seite	Ausgabe-datum	Bezug
6	6.1.1	Nov. 1995	
	6.1.2	Nov. 1995	
	6.2.1	Nov. 1995	
	6.2.2	Nov. 1995	
	6.2.3	Nov. 1995	
	6.2.4	Nov. 1995	
	6.2.5	Sept. 1997	TN 349-21
	6.2.6	Nov. 1995	
	6.2.7	Nov. 1995	

0.2 Verzeichnis der Seiten / List of effective pages

Ab-schnitt	Seite	Ausgabe-datum	Bezug
7	7.1.1	Nov. 1995	
	7.1.2	Nov. 1995	
	7.2.1	Nov. 1995	
	7.2.2	Nov. 1995	
	7.2.3	Nov. 1995	
	7.2.4	Nov. 1995	
	7.2.5	Nov. 1995	
	7.3.1	Nov. 1995	
	7.3.2	Nov. 1995	
	7.4	Nov. 1995	
	7.5	Nov. 1995	
	7.6	Nov. 1995	
	7.7	Nov. 1995	
	7.8	Nov. 1995	
	7.9.1	Nov. 1995	
	7.9.2	Nov. 1995	
	7.9.3	Nov. 1995	
	7.10	Nov. 1995	
	7.11	Nov. 1995	
	7.12.1	Nov. 1995	
7.12.2	Nov. 1995		
7.13.1	Nov. 1995		
7.13.2	Nov. 1995		

0.2 Verzeichnis der Seiten / List of effective pages

Ab-schnitt	Seite	Ausgabe-datum	Bezug
8	8.1.1	Nov. 1995	
	8.1.2	Nov. 1995	
	8.2	Nov. 1995	
	8.3	Nov. 1995	
	8.4	Nov. 1995	
	8.5.1	Nov. 1995	
	8.5.2	Nov. 1995	

0.2 Verzeichnis der Seiten / List of effective pages

Ab-schnitt	Seite	Ausgabe-datum	Bezug
9	9.1.1 9.1.2 9.2	Nov. 1995 Nov. 1995	

0.3 Table of contents

	Section
General (a non-approved section)	1
Limitations (an approved section)	2
Emergency procedures (an approved section)	3
Normal procedures (an approved section)	4
Performance (a partly approved section)	5
Weight and balance (a non-approved section)	6
Sailplane and systems description (a non-approved section)	7
Sailplane handling, care and maintenance (a non-approved section)	8
Supplements	9

Section 1

- 1. General
- 1.1 Introduction
- 1.2 Certification basis
- 1.3 Warnings, cautions and notes
- 1.4 Descriptive data
- 1.5 Three-side view

Section 2

- 2. Limitations
 - 2.1 Introduction
 - 2.2 Airspeed
 - 2.3 Airspeed indicator markings
 - 2.4 (Reserved)
 - 2.5 (Reserved)
 - 2.6 Weights (masses)
 - 2.7 Center of gravity
 - 2.8 Approved maneuvers
 - 2.9 Maneuvering load factors
 - 2.10 Flight crew
 - 2.11 Kinds of operation
 - 2.12 Minimum equipment
 - 2.13 Aerotow and winch launch
 - 2.14 Other limitations
 - 2.15 Limitation placards

Section 3

- 3. Emergency procedures
 - 3.1 Introduction
 - 3.2 Canopy jettisoning
 - 3.3 Bailing out
 - 3.4 Stall recovery
 - 3.5 Spin recovery
 - 3.6 Spiral dive recovery
 - 3.7 (reserved)
 - 3.8 (reserved)
 - 3.9 Other emergencies

Section 4

- 4. Normal operating procedures
 - 4.1 Introduction
 - 4.2 Rigging and de-rigging
 - 4.3 Daily inspection
 - 4.4 Pre-flight inspection
 - 4.5 Normal procedures and recommended speeds
 - 4.5.1 Methods of launching
 - 4.5.2 (reserved)
 - 4.5.3 Flight
 - 4.5.4 Approach
 - 4.5.5 Landing
 - 4.5.6 Flight with water ballast
 - 4.5.7 High altitude flight
 - 4.5.8 Flight in rain
 - 4.5.9 Aerobatics

Section 5

- 5. Performance
- 5.1 Introduction
- 5.2 LBA-approved data
 - 5.2.1 Airspeed indicator system calibration
 - 5.2.2 Stall speeds
 - 5.2.3 (reserved)
 - 5.2.4 Additional information
- 5.3 Additional information -
LBA-approval not required
 - 5.3.1 Demonstrated crosswind performance
 - 5.3.2 Flight polar

Section 6

6. Weight (mass) and balance

6.1 Introduction

6.2 Weight (mass) and balance record
and permitted payload range.

Determination of:

- Water ballast in wing tanks
- Water ballast in fin tank

Section 7

- 7. Description of the sailplane and its systems
 - 7.1 Introduction
 - 7.2 Cockpit description
 - 7.3 Instrument panel
 - 7.4 Undercarriage
 - 7.5 Seat and restraint system
 - 7.6 Static pressure and Pitot pressure system
 - 7.7 Airbrake system
 - 7.8 Baggage compartment
 - 7.9 Water ballast system(s)
 - 7.10 (reserved)
 - 7.11 (reserved)
 - 7.12 Electrical system
 - 7.13 Miscellaneous equipment
(removable ballast, oxygen, ELT etc.)

Section 8

- 8. Sailplane handling, care and maintenance
 - 8.1 Introduction
 - 8.2 Sailplane inspection periods
 - 8.3 Sailplane alterations or repairs
 - 8.4 Ground handling / road transport
 - 8.5 Cleaning and care

Section 9

- 9. Supplements

- 9.1 Introduction

- 9.2 List of inserted supplements

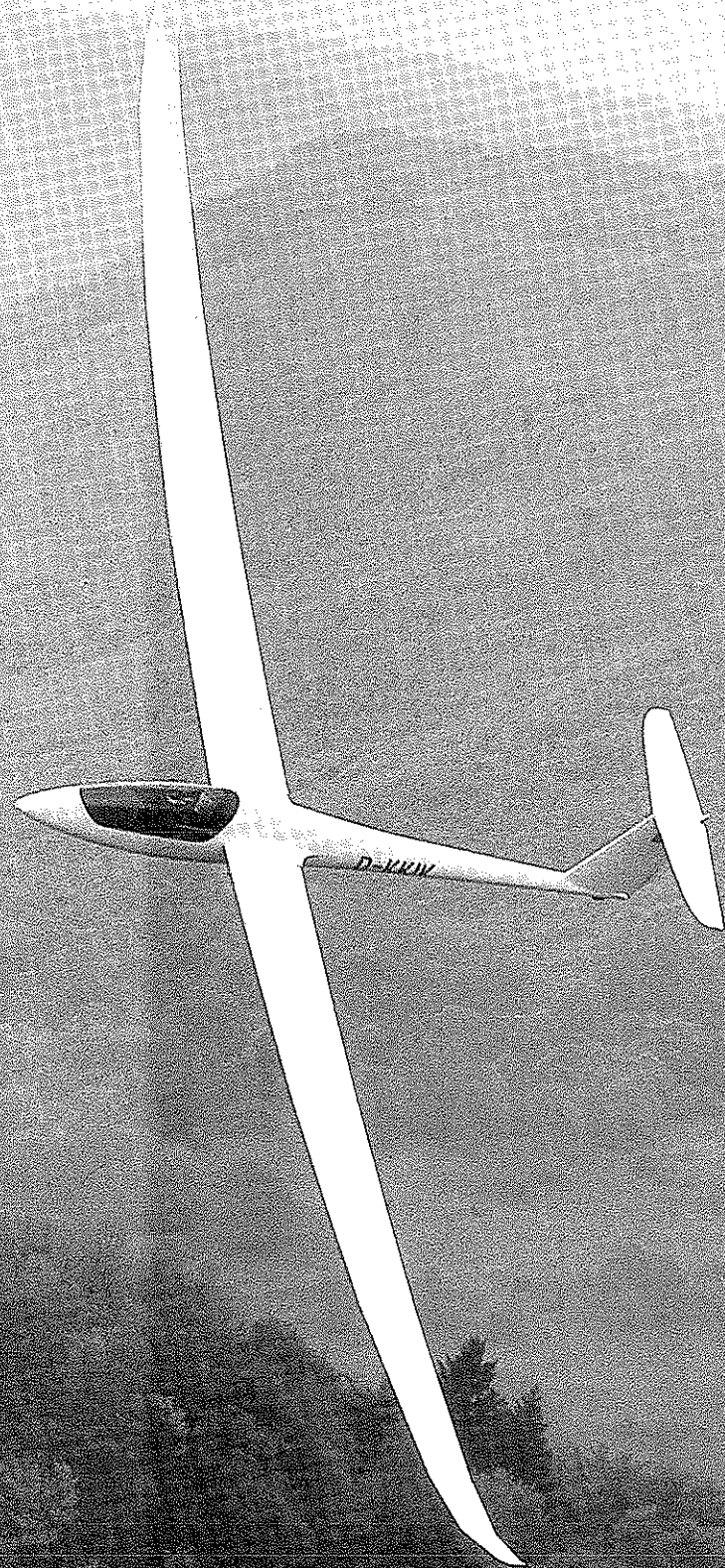

Centur-2C

Section 1

- 1. General
- 1.1 Introduction
- 1.2 Certification basis
- 1.3 Warnings, cautions and notes
- 1.4 Descriptive data
- 1.5 Three-side view

1.1 Introduction

The Flight Manual for this sailplane has been prepared to provide pilots and instructors with information for the safe and efficient operation of the "Ventus-2c".

This manual includes the material required to be furnished to the pilot by "JAR", Part 22.

It also contains supplemental data supplied by the manufacturer of the sailplane.

1.2 Certification basis

This sailplane, model designation

" Ventus-2c "

has been approved by the Luftfahrt Bundesamt (LBA) in compliance with "JAR", Part 22, effective on June 27, 1989 (Change 4 of the English Original Issue), including additional Amendment 22/90/1.

The LBA Type Certificate is No. 349 and was issued on

September 26, 1996.

Category of Airworthiness : UTILITY

1.3 Warnings, cautions and notes

The following definitions apply to warnings, cautions and notes used in this flight manual:

- "WARNING" means that the non-observation of the corresponding procedure leads to an immediate or important degradation of the flight safety
- "CAUTION" means that the non-observation of the corresponding procedure leads to a minor or to a more or less long term degradation of the flight safety
- "NOTE" draws the attention on any special item not directly related to safety, but which is important or unusual

1.4 Descriptive data

The "Ventus-2c" is a flap-equipped, single-seat high-performance sailplane, constructed from fiber reinforced plastic (FRP), featuring a T-tail (fixed horiz. stabilizer with elevator, fin and rudder). It can be flown in 15 or 18 m configuration.

Wing

The four-piece (15 or 18 m) wing is multi-stage trapezoid in planform with double-panel Schempp-Hirth type airbrakes on the upper surface. Use of the flaps to act as full-span ailerons.

The water ballast tanks are integral compartments in the fwd. section of the inbd. panels, their total capacity is approx. 174 Liter (45.97 US Gal., 38.28 IMP Gal.).

The wing shells are a carbon fiber/foam-sandwich construction with spar flanges of carbon fiber rovings and shear webs made as a carbon fiber/foam-sandwich.

Fuselage

The pilot has a semi-reclining position in the comfortable cockpit. A one-piece canopy hinges sideways and opens to the right.

For high energy absorption the cockpit region is constructed as a Kevlar/carbon and glass fiber laminate, which is reinforced by a double skin on the sides with integrated canopy coaming frame.

The aft fuselage section is a pure carbon fiber (non-sandwich-) shell, stiffened by carbon fiber bulkheads and glass fiber webs. The landing wheel is retractable and features a hydraulic disc brake; the tail wheel (or rubber skid) is fixed.

Horizontal tailplane

The horizontal tailplane consists of a fixed stabilizer with elevator. The stabilizer is a glass fiber/foam sandwich, the elevator halves are a pure glass fiber lay-up. The automatic elevator trim is linked to the flap actuating rod and is infinitely adjustable.

Vertical tail

Fin and rudder are a glass fiber/foam-sandwich construction. On request a water ballast trim tank with a capacity of 6.0 Liter (1.59 US Gal., 1.32 IMP Gal.) is provided in the fin.

Controls

On rigging the wing panels, the control surfaces are automatically hooked up.

- INTENTIONALLY LEFT BLANK -

TECHNICAL DATAWing

Span	15.00 m 49.21 ft	18.00 m 59.06 ft
Area	9.67 m ² 104.09 ft ²	11.00 m ² 118.40 ft ²
Aspect ratio	23.3	29.5
MAC	0.673 m 2.21 ft	0.648 m 2.13 ft

Fuselage

Length	6.78 m 22.24 ft
Width	0.62 m 2.03 ft
Height	0.81 m 2.66 ft

Weight

Empty mass approx.	257 kg 567 lb	265 kg 584 lb
Max. all-up mass	525 kg 1157 lb	
Wing loading	33.8-54.3 kg/m ² 6.9-11.1 lb/ft ²	30.5-47.7 kg/m ² 6.2- 9.8 lb/ft ²

Ventus-2c

1.5 Three-side view

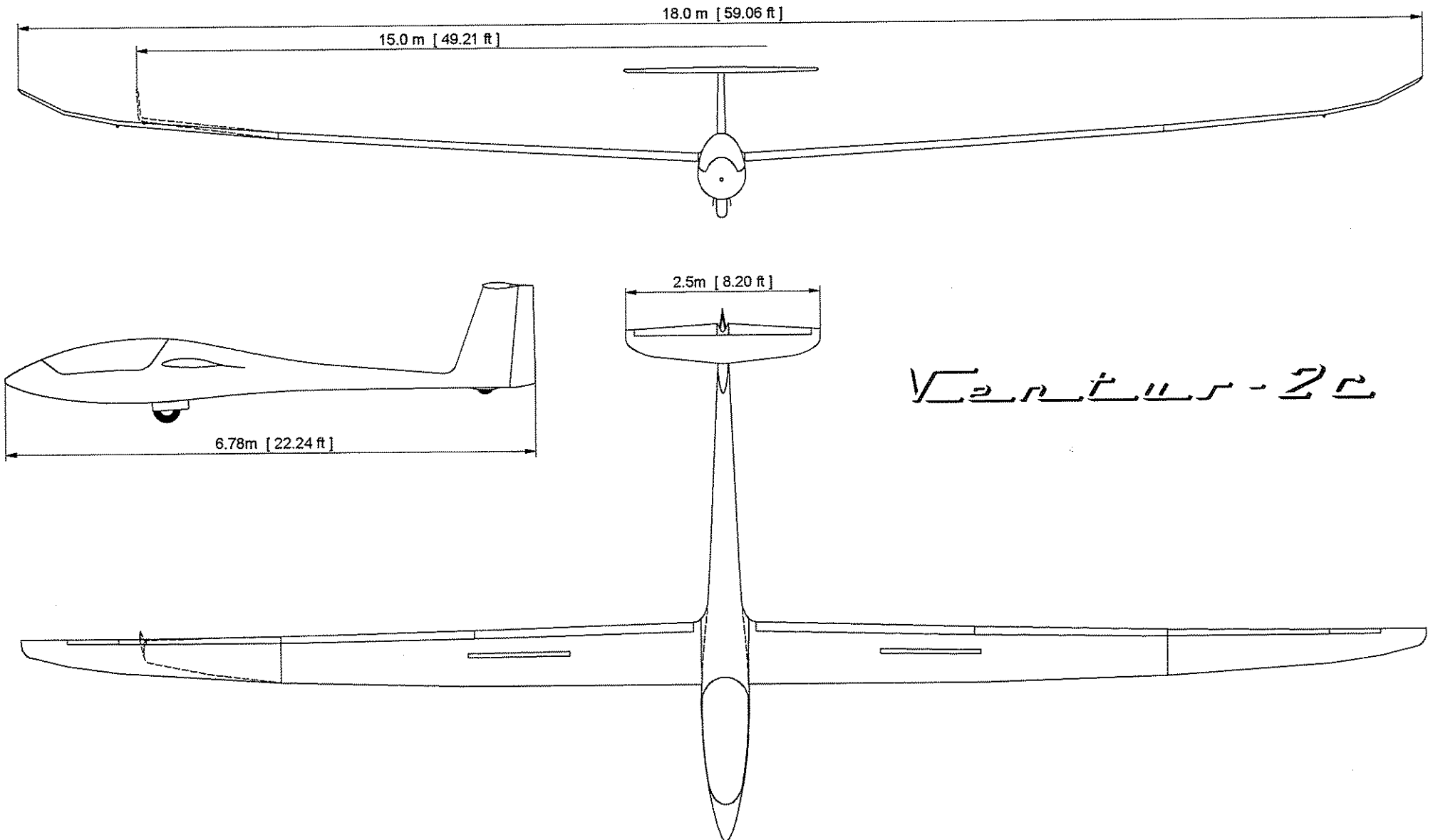

Section 2

- 2. Limitations
 - 2.1 Introduction
 - 2.2 Airspeed
 - 2.3 Airspeed indicator markings
 - 2.4 (Reserved)
 - 2.5 (Reserved)
 - 2.6 Weights (masses)
 - 2.7 Center of gravity
 - 2.8 Approved maneuvers
 - 2.9 Maneuvering load factors
 - 2.10 Flight crew
 - 2.11 Kinds of operation
 - 2.12 Minimum equipment
 - 2.13 Aerotow and winch launch
 - 2.14 Other limitations
 - 2.15 Limitation placards

2.1 Introduction

Section 2 includes operating limitations, instrument markings and basic placards necessary for safely operating the sailplane, its standard systems and standard equipment.

The limitations included in this section and in section 9 have been approved by the Luftfahrt Bundesamt (LBA), Braunschweig.

2.2 Airspeed

Airspeed limitations and their operational significance are shown below:

	SPEED	(IAS)	REMARKS
V_{NE}	Never exceed speed in calm air. Flaps set at "-1", "-2", "S" or "S1"	270 km/h 146 kt 168 mph	Do not exceed this speed in any operation and do not use more than 1/3 of control deflection.
V_{RA}	Rough air speed	180 km/h 97 kt 112 mph	Do not exceed this speed except in smooth air, and then only with caution. Rough air is met in lee-wave rotors, thunderclouds etc.
V_A	Maneuvering speed	180 km/h 97 kt 112 mph	Do not make full or abrupt control movements above this speed as the aircraft structure might get overstressed.
V_{FE}	Maximum "flap extended" speed Flaps set at "0"	160 km/h 86 kt 99 mph	Do not exceed these speeds with the given flap setting.
	Flaps set at "+2" or "+1"	160 km/h 86 kt 99 mph	
	Flaps set at "L"	160 km/h 86 kt 99 mph	
V_T	Maximum speed on aerotow	180 km/h 97 kt 112 mph	Do not exceed this speed during an aerotow.
V_W	Maximum winch launch speed	150 km/h 81 kt 93 mph	Do not exceed this speed during a winch launch.
V_{LO}	Maximum landing gear operating speed	180 km/h 97 kt 112 mph	Do not extend or retract landing gear above this speed.

2.3 Airspeed indicator markings

Airspeed indicator markings and their colour code significance are shown below:

MARKING	VALUE OR RANGE (IAS)	SIGNIFICANCE
White arc	92 - 160 km/h 50 - 86 kt 57 - 99 mph	<u>Positive flap operating range</u> (lower limit is the speed $1.1 V_{SO}$ at maximum mass and in landing configuration. Upper limit is the maximum speed permissible with flaps extended positive).
Green arc	102 - 180 km/h 55 - 97 kt 63 - 112 mph	<u>Normal operating range</u> (lower limit is the speed $1.1 V_{S1}$ at maximum mass, most forward c/g position and flaps at the neutral "-1" position. Upper limit is the permissible speed in rough air).
Yellow arc	180 - 270 km/h 97 - 146 kt 112 - 168 mph	Maneuvers must be conducted with caution and operating in rough air is not permitted.
Red line at	270 km/h 146 kt 168 mph	Maximum speed for all operations
Yellow triangle at	100 km/h 54 kt 62 mph	Approach speed at maximum mass without water ballast

- INTENTIONALLY LEFT BLANK -

- INTENTIONALLY LEFT BLANK -

Ventus-2c

FLIGHT MANUAL

2.6 Weights (masses)

Wing span	15 m	18 m
Maximum permitted take-off mass :	525 kg	1157 lb
Maximum permitted landing mass :	525 kg	1157 lb
Maximum permitted take-off and landing mass without water ballast :	383 kg	391 kg 844 lb 862 lb
Maximum permitted mass of all non-lifting parts :	250 kg	551 lb
Maximum permitted mass in baggage compartment :	2.0 kg	4.4 lb

2.7 Center of gravityCenter of gravity in flight

Sailplane attitude : Tail jacked up such that a wedge-shaped block, 100 : 4.4, placed on the rear top fuselage, is horizontal along its upper edge.

Datum : Wing leading edge at root rib

Maximum forward
c/g position : 250 mm (9.84 in.) aft of datum

Maximum rearward
c/g position : 380 mm (14.96 in.) aft of datum

It is extremely important that the maximum rearward c/g position is not exceeded.

This requirement is met when the minimum seat load is observed.

The minimum seat load is given in the loading table and is shown by a placard in the cockpit.

A lower seat load must be compensated by ballast - see section 6.2: "Weight and Balance Record / Permitted Seat Load Range".

2.8 Approved maneuvers

The sailplane model "Ventus-2c" is certified in category

U T I L I T Y.

In 15 m configuration and without water ballast the following aerobatic maneuvers are permitted:

- a) Inside loops
- b) Stalled turns
- c) Lazy Eight

It is recommended that in addition to the instrumentation listed in section 2.12 an accelerometer (3 hands, resettable) is installed.

2.9 Maneuvering load factors

The following maneuvering load factors must not be exceeded when the sailplane is pulled up:

- a) At $V_A = 180$ km/h (97 kt, 112 mph)
with airbrakes closed :
- | |
|--------------|
| $n = + 5.3$ |
| $n = - 2.65$ |

- At $V_{NE} = 270$ km/h (146 kt, 168 mph)
with airbrakes closed :
- | |
|-------------|
| $n = + 4.0$ |
| $n = - 1.5$ |

With flaps set as follows:

Setting		L	+2, +1	0	-1, -2 S, S1
Speed	km/h	160	160	160	270
	kt	86	86	86	146
	mph	99	99	99	168
Load factor	n	4.0	5.3	5.3	4.0

- b) With airbrakes extended, the maximum maneuvering load factor is

$$n = + 3.5 \text{ at } V_{NE}$$

2.10 Flight crew

The "Ventus-2c" is single-seated - its minimum seat load must be observed.

If necessary, ballast must be used to bring the load up to a permissible figure.

See also section 6.2: "Weight & Balance Record / Permitted Seat Load Range".

2.11 Kinds of operation

With the prescribed minimum equipment installed (see page 2.12), the "Ventus-2c" is approved for

1. VFR-flying in daytime
2. Cloud flying
(in 15 m configuration only)
3. Restricted aerobatics
(in 15 m configuration only)

Cloud flying is only permissible without water ballast.

The operating conditions for restricted aerobatics are shown on page 2.8.

2.12 Minimum equipment

Instruments and other basic equipment must be of an approved type and should be selected from the list in the Maintenance Manual.

a) Normal operations

- 1 Airspeed indicator
(range up to 300 km/h, 162 kt, 186 mph)
with colour markings according to page 2.3
- 1 Altimeter
- 1 Outside air temperature indicator with sensor (when flying with water ballast - red line at +2^o C)
- 1 Four-piece safety harness (symmetrical)
- 1 Automatic or manual parachute
or
- 1 Back cushion (thickness approx. 10 cm/
3.9 in. when compressed)

CAUTION: The sensor for the OAT must be installed in the ventilation air intake.

For structural reasons the mass of the instrument panel with instruments in place (incl. those of section "b") must not exceed 10 kg (22 lb).

b) Cloud flying (only permissible in 15 m configuration and without water ballast)

In addition to the minimum equipment listed under a) the following is required:

- 1 Turn & bank indicator with slip ball
- 1 Variometer
- 1 VHF-Transceiver

NOTE : From experience gained to date it appears that the ASI system installed remains fully operational when flying in clouds.

Recommended additional equipment for cloud flying:

- 1 Artificial horizon
- 1 Clock

Recommended additional equipment for restricted aerobatics (only permissible in 15 m configuration and without water ballast)

- 1 Accelerometer (3 hands, resettable)

2.13 Aerotow and winch launchAerotow

Maximum towing speed :	180 km/h (97 kt, 112 mph)
Weak link in tow rope :	525 - 680 daN (1157 - 1499 lb)
Minimum length of tow rope :	30 m (98 ft)
Tow rope material :	Hemp or Nylon

Winch launch

Max. launching speed :	150 km/h (81 kt, 93 mph)
Weak link in winch cable :	525 - 680 daN (1157 - 1499 lb)

2.14 Further limitations

N o n e

2.15 Limitation placards

MAXIMUM PERMITTED ALL-UP MASS			
For 15 m and 18 m span	1157 lb / 525 kg		
MAXIMUM PERMITTED SPEEDS (IAS) : km/h kt mph			
Flap setting -1, -2, S, S1	270	146	168
Flap setting L, +2, +1, 0	160	86	99
Rough air speed	180	97	112
Maneuvering speed	180	97	112
Aerotowing speed	180	97	112
Winch/auto launching speed	150	81	93
Landing gear operating speed	180	97	112

LOAD ON PILOT'S SEAT (pilot and parachute)
Minimum load: 70* kg/ 154* lb
Maximum load: 110* kg/ 243* lb
For seat loads below placarded minimum refer to Flight Manual, section 6.2

* As the actual minimum or maximum seat load of the sailplane (to which this manual refers) may differ from these typical weights, the placard in the cockpit must always show the actual values, which are also to be entered in the log chart - see page 6.2.3.

WEAK LINK FOR TOWING	
Maximum 680 daN (1499 lb)	
TIRE PRESSURE	
Main wheel:	4.0 bar (58 psi)
Tail wheel : (if installed)	2.0 bar (29 psi)

For further placards refer to the Maintenance Manual.

Section 3

- 3. Emergency procedures
- 3.1 Introduction
- 3.2 Canopy jettisoning
- 3.3 Bailing out
- 3.4 Stall recovery
- 3.5 Spin recovery
- 3.6 Spiral dive recovery
- 3.7 (reserved)
- 3.8 (reserved)
- 3.9 Other emergencies ,

3. Emergency procedures

3.1 Introduction

Section 3 provides check lists and amplifies procedures for coping with emergencies that may occur.

Emergency situations can be minimized by proper pre-flight inspections and maintenance.

3.2 Jettisoning the canopy

The canopy is to be jettisoned as follows:

Swing b a c k (approx. 90°) red lever on port canopy frame up to its stop and swing canopy sideways fully open.

The canopy will then be torn out from its hinges by the airstream and gets carried away.

3.3 Bailing out

With the canopy gone, the pilot may bail out.

As the canopy coaming frame on the fuselage is made from laminated hybrid fabrics - so that it is strong and without sharp edges - the pilot can grab it and use it as a support when bailing out.

The forward hinged instrument panel rises under light pressure by hand or with the legs, thus allowing for an easier emergency exit.

3.4 Stall recovery

On stalling whilst flying straight ahead or in a banked turn, normal flying attitude is regained by firmly easing the control stick forward and, if necessary, applying opposite rudder and aileron.

3.5 Spin recovery

A safe recovery from a spin is effected by the following method:

- a) Hold ailerons neutral.
- b) Apply opposite rudder (i.e. against the direction of rotation of the spin).
- c) Ease control stick forward until rotation ceases and the airflow is restored.
- d) Centralize rudder and pull gently out of dive.

With the center of gravity in rearward positions, a steady spinning motion is possible. After having applied the standard recovery method, the sailplane will stop rotating after about 1/4 to 3/4 of a turn.

The loss of height, from the point at which recovery is initiated to the point at which horizontal flight is first regained, can be up to about 120 m (394 ft).

The recovery speeds are between 120 and 210 km/h (65-113 kt, 75-130 mph), depending on the flap setting.

At positive flap settings and high all-up masses a resetting of the flaps at "-1" may be required so as to avoid exceeding their speed limits when pulling out of the dive.

With the center of gravity in foremost position, a steady spinning motion is not possible - the sailplane stops rotating after a half to three full turns and, depending on the control surface deflections, usually enters a spiral dive or a side slip or steepens its nose-down attitude.

Recovery is by normal use of opposite controls.

NOTE:

1. Spinning may safely be avoided by following the actions given in section 3.4 "Stall recovery".
2. If the sailplane with a rearmost c of g position and an uneven ballast load in the wing tanks enters a spin, it may only stop rotating after 1.5 turns following initiating recovery.

3.6 Spiral dive recovery

With the center of gravity in a forward position, a spin - depending on flap setting and use of controls - may turn into a spiral dive, which is indicated by a rapid increase in speed and acceleration.

Recovery from a spiral dive is achieved by easing the control stick forward and applying opposite rudder and aileron.

WARNING:

When pulling out of the dive, the limiting airspeeds for the various flap settings (if necessary, reset flaps at "-1") and the permissible control surface deflections at V_A/V_{NE} (see page 2.2) must be observed.

3.7 - INTENTIONALLY LEFT BLANK -

3.8 - INTENTIONALLY LEFT BLANK -

3.9 Other emergenciesFlying with uneven water ballast

If, on dumping water ballast, the wing tanks are emptying unevenly or only on one side - which is recognized at lower speeds by having to apply opposite aileron for normal flying attitude - entering a stall must be avoided.

When landing in this condition, the touch down speed must be increased by about 10 km/h (5 kt, 6 mph) and the pilot must be prepared for the sailplane to veer off course as the heavier wing tends to drop somewhat sooner than normal (apply opposite aileron).

Jammed elevator or flap control

While jammed flaps will just result in a "fixed profile flight behaviour", a jammed elevator control is more serious.

The pilot, however, should take into consideration that the sailplane is still controllable to at least some extent by using its flaps for longitudinal control:

Flap lever pulled back = slower
 Flap lever pushed forward = faster

This may allow the pilot to move over to a more favourable bail-out area or he may even avoid an emergency exit.

Loss of directional control

Should a rudder control cable break in flight, the sailplane may quickly start yawing and rolling. An ensuing spiral dive (in 18 m config. only), however, may possibly be avoided by resetting the flaps immediately at "0".

If the yawing/rolling motion cannot be stopped by normal opposite aileron, then briefly apply aileron in the direction of the roll so that the wing will level with the aid of the adverse aileron yaw.

Shallow turns can also be effected by using only the aileron in the described manner.

Emergency landing with retracted undercarriage

An emergency landing with the main wheel retracted is on principle not recommended, because the potential energy absorption of the landing gear is many times higher as compared to the fuselage shell.

Should the wheel fail to extend, the sailplane should be landed at a flat angle, with flaps set at "L" and without pancaking.

Ground loop

If there is the danger of the sailplane overshooting the boundary of the landing field selected, a decision whether or not to initiate a controlled ground loop should be made at least 40 m (131 ft) away from the boundary:

- If possible, always turn into the wind and
- as the wing tip is forced down, push the control stick forward simultaneously.

Emergency water landing

From experience gained on the occasion of a composite sailplane landing on water with its undercarriage retracted, the pilot must take into consideration that, in the case of this aircraft, the entire cockpit might get forced under water.

Therefore an emergency landing on water should only be chosen as a last resort and the wheel should always be extended.

Section 4

- 4. Normal operating procedures
 - 4.1 Introduction
 - 4.2 Rigging and de-rigging
 - 4.3 Daily inspection
 - 4.4 Pre-flight inspection
 - 4.5 Normal procedures and recommended speeds
 - 4.5.1 Methods of launching
 - 4.5.2 (reserved)
 - 4.5.3 Flight
 - 4.5.4 Approach
 - 4.5.5 Landing
 - 4.5.6 Flight with water ballast
 - 4.5.7 High altitude flight
 - 4.5.8 Flight in rain
 - 4.5.9 Aerobatics

4. Normal operating procedures

4.1 Introduction

Normal procedures associated with optional equipment are found in section 9.

This section provides check lists and amplifies procedures for conducting the daily and pre-flight inspection.

Furthermore this section includes normal operating procedures and recommended speeds.

4.2 Rigging and de-rigging

Rigging

Rigging can be done by two people if a wing stand or trestle is placed under the tip of one inboard wing panel.

Prior to rigging, all connecting points (pins and corresponding bearings) on fuselage, wing and tail-plane should be cleaned and greased.

Rigging should then be done as follows:

Keep main wing pin ready in the cockpit, set flap lever at "0", unlock airbrake handle and set water ballast control knob at "closed" (for tanks closed).

Inboard wing panels

Insert spar stub of port wing panel into fuselage cut-out - concentrate on lifting the trailing edge also, check that the spar stub tip is located correctly on the far side of the fuselage and ensure that the angular levers on the root rib are definitely inserted into their fuselage funnels (do not raise aileron).

Now push panel home until its locating pins have fully engaged in their corresponding fuselage bearings and push in the main wing pin for about 30 to 40 mm (1.2-1.6 in.) so that the panel is prevented from sliding out by the GFRP laminate covering the front wing suspension tube. The panel tip may now be placed on a wing stand.

Check once more that the airbrakes are unlocked, insert spar stub of starboard panel (observe same criteria as on port wing), lift leading edge slightly and push panel in until its locating pins have just engaged in their bearings on the fuselage (with stub pins still clear of their bearing on the opposing root rib). Thereafter move the starboard panel gently fore and aft and push it home under vigorous pressure.

Finally push the main wing pin fully home and secure its handle (depress locking pin and let it engage in the bracket on the panel covering the fuselage center frame).

Outboard wing panels (15 or 18 m span)

Take round-headed rigging tool, screw it into wing pin locking lever (on outbd. panel) and swing the latter upwards, thus extracting the pin from the spar stub tunnel.

Thereafter slide outboard panel onto spar stub of inboard panel until stub pin has just engaged in its corresponding bushing on the outbd. panel, align aileron coupling lap with slot on adjacent aileron (on inbd. wing) and push panel fully home.

Finally swing wing pin locking lever down (its upper edge must not protrude above wing surface) and remove rigging tool.

Horizontal tailplane

Take the round-headed rigging tool (to be stored in the side pocket) and screw it into the front tailplane locating pin on the leading edge of the fin.

Next slide the horiz. tailplane aft onto the two elevator actuating pins, pull rigging tool and its pin forwards, seat stabilizer nose and push locating pin home into the front tailplane attachment fitting.

Remove rigging tool - the locating pin must not protrude in front of the leading edge of the fin.

Check whether the elevator actuating pins are really located by moving the elevator.

After rigging

Check the controls - with the aid of a helper - for full and free movement in the correct sense.

Use tape to seal off the wing/fuselage joint, the joint between inboard and outboard panels, the opening for the front tailplane attachment pin and also the joint between fin and horizontal stabilizer (only necessary if there is no rubber seal at the top of the fin).

Sealing with tape is beneficial in terms of performance and it also serves to reduce the noise level.

De-rigging

Remove sealing tape from wing panels and tailplane.

Outboard wing panels

Swing up locking lever with the aid of the tailplane rigging tool and carefully pull off outbd. panel(s).

Horizontal tailplane

Using the threaded rigging pin, pull out front tailplane attachment pin, lift stabilizer leading edge slightly and pull tailplane forwards and off.

Inboard wing panels

Unlock airbrakes, set water ballast control knob to the "closed" position, unlock handle of main wing pin and set flaps at "0".

With a helper at the tip of each inboard panel pull out main wing pin up to the last 20 to 30 mm (0.8 - 1.2 in.) and withdraw the starboard panel by gently rocking it backwards and forwards if necessary.

Thereafter remove main wing pin and withdraw port wing panel.

4.3 Daily inspection

The importance of inspecting the sailplane after rigging and before commencing the day's flying cannot be over-emphasized, as accidents often occur when these daily inspections are neglected or carried out carelessly.

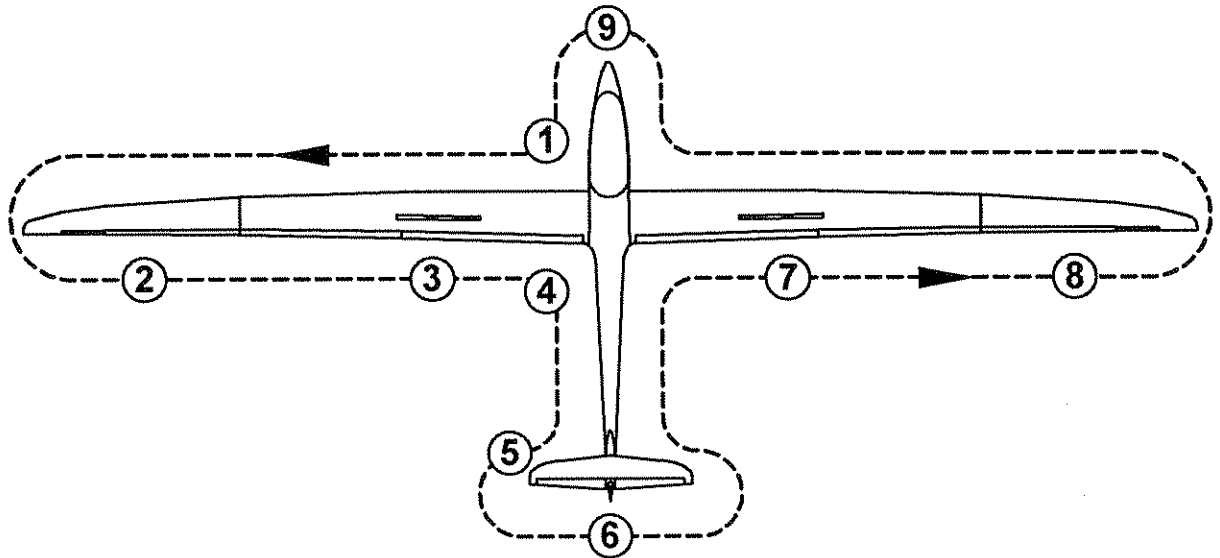

When walking around the sailplane, check all surfaces for paint cracks, dents and unevenness.

In case of doubt, ask an expert for his advice.

- 1) a) Open the canopy and check gas strut raising the instrument panel for proper function
- b) Check that the main wing pin is properly secured
- c) Make a visual check of all accessible control circuits in the cockpit
- d) 1. Check for full and free movements of the control elements
2. Check batteries for firm attachment

- e) Check for the presence of foreign objects
- f) (reserved)
- g) (reserved)
- h) Check main wheel tire pressure:
4.0 bar / 58 psi (see placard)
- i) Check tow release mechanism(s) for proper condition and function

2

- a) Check upper and lower wing surfaces for damage
- b) Clean and grease water dump valves (if necessary)
- c) Check outboard wing panels for proper connection (locking lever must be below upper wing surface)
- d) Check that the ailerons are in good condition and operate freely.
Check for any unusual play by gently shaking the trailing edge. Check hinges for damage

3

- a) Check inbd. ailerons (flaperons) for proper condition and free movement.
Check for any unusual play by gently shaking the trailing edge. Check hinges for damage
- b) Check airbrakes for proper condition, fit and locking

4

- a) Check fuselage for damage, especially on its lower side
- b) Check that the STATIC pressure ports for the airspeed indicator on the tail boom (0.8 m/ 2.62 ft forward of the base of the fin) and below the spar stub cut-out are clear

5

- a) Check condition of tail skid or wheel. If the latter is installed, check tire pressure:
2.0 bar / 29 psi (see placard)
- b) Should a total energy compensation probe be used, mount it (head pointing upwards) and check the line (when blowing gently into the probe, the variometer(s) connected should read "climb")
- c) Check that the fin-mounted PITOT tube is clear. When blowing gently into this tube, the airspeed indicator must register

Should a water ballast fin tank be installed (option):

- d) Check that the fin tank spill holes are clear
- e) Check water ballast level in fin tank (in case of doubt, discharge ballast)
- f) Check that the fin tank dump hole in the fairing of the tail wheel (if installed) is clear

- 6)
 - a) Check horizontal tailplane for proper attachment and locking
 - b) Check elevator and rudder for free movement
 - c) Check trailing edge of elevator and rudder for damage
 - d) Check elevator and rudder for any unusual play by gently shaking the trailing edge
- 7) See (3)
- 8) See (2)
- 9) (Reserved)

After heavy landings or after the sailplane has been subjected to excessive loads, the resonant wing vibration frequency should be checked (its value to be extracted from the last inspection report for this serial number).

Check the entire sailplane thoroughly for surface cracks and other damage. For this purpose it should be de-rigged.

If damage is discovered (e.g. surface cracks in the fuselage tail boom or tailplane, or if delamination is found at the wing roots or at the bearings in the root ribs), then the sailplane must be grounded until the damage has been repaired by a qualified person.

4.4 Pre-flight inspection

CHECK LIST BEFORE TAKE-OFF

- Water ballast in fin tank ? (if installed)
- Loading charts checked ?
- Parachute securely fastened ?
- Safety harness secured and tight ?
- Seat back and pedals in comfortable position ?
- All controls and instruments easily accessible ?
- Airbrakes checked and locked ?
- All control surfaces checked with assistant for full and free movement in correct sense ?
- Trim correctly set ?
- Flaps set for take-off ?
- Canopy closed and locked ?

4.5 Normal operating procedures and recommended speeds4.5.1 Methods of launchingAerotow

(only permissible with nose tow release in place)

Maximum permitted towing speed:

$$V_T = 180 \text{ km/h (97 kt, 112 mph)}$$

For aerotow only the nose tow release must be used - hemp and nylon ropes of between 30 and 40 m length (98-131 ft) were tested.

Prior to take-off - to be commenced with flap setting "0" - set the elevator trim as follows:

- Rearward c/g positions : Lever forward to first third of its travel
- Other c/g positions : Lever to the middle of its travel

As the tow rope tightens, apply the wheel brake gently (by actuating the stick-mounted lever) to prevent the sailplane from overrunning the rope.

In crosswind conditions the aileron control should be held towards the downwind wing, i.e. in winds from the left the stick should be displaced to the right.

This is to counteract the lift increase on the right wing generated by the tug's prop wake, which the crosswind forces to drift to the right.

For intermediate to forward c/g positions the elevator should be neutral for the ground run; in the case of rearward c/g positions it is recommended that down elevator is applied until the tail lifts.

For rearward c/g positions and low all-up masses the sailplane is lifted off with flaps set at "0".

In the case of forward c/g positions or high all-up masses even setting "+1" may be used to shorten the ground roll distance.

After lift-off, between about 80 to 90 km/h (43-49 kt, 50-56 mph), depending on wing loading and flap setting, the elevator trim (if necessary) can be set for minimum control stick loads.

With flaps set at "0", normal towing speed is in the region of 110 to 130 km/h (59-70 kt, 68-81 mph) and between about 120 to 140 km/h (65-76 kt, 75-87 mph) for high all-up masses.

At higher towing speeds and low all-up masses, i.e. above about 150 to 160 km/h (81-86 kt, 93-99 mph), flap setting "-1" or "-2" should be used (see diagram below). With these settings, speeds up to V_T are covered by the elevator trim.

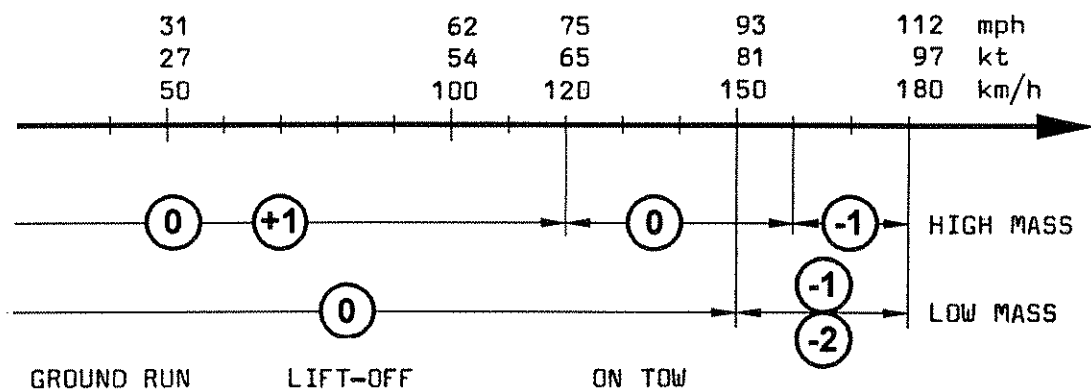

Only small control surface deflections are necessary to keep station behind the tug.

In gusty conditions or when flying into the propeller slip stream of a powerful tug, correspondingly greater control stick movements are required.

At lower speeds the undercarriage may be retracted during the tow; this is not, however, recommended at low altitude, because changing hands on the stick could easily cause the sailplane to lose station behind the tug.

When releasing the tow rope, pull the yellow T-shaped handle fully several times and turn only when definitely clear of the rope.

Winch launch

(only permissible with c/g tow release in place)

Maximum permitted launching speed:

$$V_W = 150 \text{ km/h (81 kt, 93 mph)}$$

For winch launching only the c/g tow release must be used.

Prior to take-off - with flaps to be at setting "+1" - set the elevator trim as follows:

- Rearward c/g positions : Knob fully forward
- Intermediate c/g positions : Knob forward to first quarter of its travel
- Forward c/g positions : Knob to the middle of its travel

As the cable tightens, apply the wheel brake gently (via stick-mounted lever) to prevent the sailplane from overrunning the winch cable.

Ground roll and lift-off are normal - there is no tendency to veer-off or to climb excessively steeply on leaving the ground.

Depending on the load on the seat, the sailplane is lifted off with the control stick almost fully pushed forward in the case of aft c/g positions and slightly pulled back with the c/g in a forward position.

After climbing to a safe height, the transition into a typical steep winch launch attitude is effected by pulling the control stick slightly further back.

At normal all-up masses, i.e. without water ballast, the launch speed should not be less than 90 km/h (49 kt, 56 mph), and with water ballast not less than 100 to 110 km/h (54-59 kt, 62-68 mph).

Normal launch speed is about 100 km/h (54 kt, 62 mph), with water ballast about 115 to 125 km/h (62-67 kt, 71-78 mph).

At the top of the launch the cable will normally back-release automatically; the cable release handle should, nevertheless, be pulled firmly several times to ensure that the cable has actually gone.

CAUTION:

Winch launching at the maximum permitted all-up mass of 525 kg (1157 lb) should only be done if there is an appropriately powerful winch and a cable in perfect condition available.

Furthermore there is not much point in launching by winch for a soaring flight, if the release height gained is less than 300 m (984 ft).

In case of doubt, reduce all-up mass to e.g. 430 kg (948 lb) or less.

Winch launching with water ballast is not recommended if the head wind is less than 20 km/h (11 kt).

<p><u>WARNING:</u> It is explicitly advised against winch launching with a tail wind!</p>
--

CAUTION:

Prior to launching by winch, the pilot must make sure that he is properly seated and able to reach all the control elements.

Particularly when using seat cushions it must be ensured that during the initial acceleration and while in the steep climbing attitude the pilot does not slide backwards and up.

4.5.2 - INTENTIONALLY LEFT BLANK -

4.5.3 Flight

The sailplane has pleasant flight characteristics and can be flown effortlessly at all speeds, loading conditions (with or without water ballast), configurations and c/g positions.

As the elevator trim is linked to the flaps, it should be set such that there is no load on the control stick at a speed of about 110 to 120 km/h (59-65 kt, 68-75 mph) with flaps set at "0".

The green knurled knob is then opposite the green marking on the edge of the seat pan cut-out. Then the sailplane is practically always well trimmed for all other flap settings and for optimum performance within their speed range.

With a mid-point c/g position the speed range covered by the trim is from about 65 km/h (35 kt, 40 mph) with flaps set at "L" to about 220 km/h (119 kt, 137 mph) with flaps set at "S1".

The controls are well harmonized - reversing a turn from + 45° to - 45° is possible without any skidding. Ailerons and rudder may be used to the limits of their travel.

Wing span		15 m	15 m	18 m	18 m
All-up mass		320 kg 705 lb	525 kg 1157 lb	416 kg 917 lb	525 kg 1157 lb
Flap setting		+ 2	+ 2	+ 2	+ 2
Speed	km/h	88	120	104	118
	kt	48	65	56	64
	mph	55	75	65	73
Reversal time	sec	3.2	3.0	4.8	3.7

NOTE:

Flights in conditions conducive to lightning strikes must be avoided.

High speed flying

When flying at high speeds, particular attention must be paid to the maximum speed limits associated with the various flap settings. These speeds are clearly visible markings on the airspeed indicator (ASI) in different colours.

Full deflections of control surfaces may only be applied up to $V_A = 180$ km/h (97 kt, 112 mph).

At $V_{NE} = 270$ km/h (146 kt, 168 mph) only one third (1/3) of the full deflection range is permissible. Avoid especially sudden elevator control movements.

In strong turbulence, i.e. in wave rotors, thunderclouds, visible whirlwinds or when crossing mountain ridges, the speed in rough air $V_{RA} = 180$ km/h (97 kt, 112 mph) must not be exceeded.

With the c/g at an aft position, the control stick movement from the point of stall to maximum permissible speed is relatively small, though the change in speed will be noticed through a perceptible change in control stick loads.

The airbrakes may be extended up to $V_{NE} = 270$ km/h (146 kt, 168 mph). However, they should only be used at such high speeds in emergency or if the maximum permitted speeds are being exceeded inadvertently.

On extending the airbrakes, high deceleration forces will occur.

WARNING:

Consequently it is wise to check in advance that the harness is tight and that the control stick is not inadvertently thrown forwards when the airbrakes are extended. Avoid loose objects in the cockpit. At speeds above 200 km/h (108 kt, 124 mph) extend the airbrakes only gradually (allow 2 seconds).

It should also be noted that in a dive with the airbrakes extended, the sailplane should be pulled out less abruptly than with retracted brakes (see section 2.9 "Maneuvering load factors").

A dive at V_{NE} (270 km/h, 146 kt, 168 mph) with airbrakes fully extended and at maximum permitted all-up mass is limited to an angle to the horizon of about 30° and to about 45° at the maximum mass without water ballast and 15 m wing span.

Use of the wing flaps

The camber-changing flaps alter the wing section such that the laminar bucket is always well suited to the actual flying speed.

Use of flaps for	flaps at	WING SPAN = 18 m OPTIMUM AIRSPEED in km/h			WING SPAN = 15 m OPTIMUM AIRSPEED in km/h		
		AUW=380 kg	AUW=450 kg	AUW=525 kg	AUW=380 kg	AUW=430 kg	AUW=525 kg
Low speed flying (straight and level)	L	- 70	- 77	- 83	- 75	- 80	- 90
	+2,+1	70- 85	77- 93	83-100	75- 90	80- 97	90-107
Best L/D	-1	95-105	104-115	113-125	102-113	108-120	120-132
Interthermal and high speed flying	-1	105-135	115-150	125-160	113-145	120-155	132-170
	-2	135-160	150-175	160-190	145-172	155-183	170-200
	S	160-200	175-220	190-240	172-215	183-230	200-250
	S1	200-270	220-270	240-270	215-270	230-270	250-270

For a speed polar diagram refer to section 5.3.2.

For smooth thermals flap setting "+2" is recommended; in turbulent thermals, which require a quick aileron response, flap setting "+1" is advantageous.

Near the lower end of the optimum thermalling speeds the pilot may even use flap setting "L", especially at high all-up masses or in updrafts with hardly any variation in flying speed.

Best glide and moderate inter-thermal speeds are covered by flap setting "-1" - for high cruise the optimum performance is achieved with the more negative settings.

Low speed flight and stall behaviour

In order to become familiar with the sailplane it is recommended to explore its low speed and stall characteristics at a safe height. This should be done using the various flap settings whilst flying straight ahead and also whilst in a 45° banked turn.

Wings level stall

Stall warning usually occurs 5 to 10 km/h (3-5 kt, 3-6 mph) above stalling speed.

It begins with a slight rolling motion and vibration in the controls. If the stick is pulled further back, these effects become more pronounced, the ailerons get spongy and the sailplane sometimes tends to slight pitching motions (speed increases again and will then drop to stalling speed).

NOTE: After reaching stalling speed, the ASI reading drops quickly by 5 to 10 km/h (3-5 kt, 3-6 mph) and starts oscillating because of the turbulent airflow affecting the Pitot pressure head.

When reaching a stalled condition with the c/g in rearward positions, the sailplane will drop a wing.

A normal flight attitude is regained by easing the stick firmly forward and - if necessary - applying opposite rudder and aileron.

The loss of height from the beginning of the stall until regaining a normal level flight attitude is up to 40 m (131 ft).

In the case of forward c/g positions and stick fully pulled back, the sailplane just continues to fly in a mushed condition without the nose or a wing dropping.

Normal flying attitude is regained by easing the control stick forward.

Turning flight stalls

When stalled during a coordinated 45° banked turn with the c/g at an aft position, the sailplane rolls slightly into the turn and, when easing the stick forward, slightly drops its nose - thereafter a normal flying attitude is regained by applying opposite rudder and aileron. There is no uncontrollable tendency for the sailplane to enter a spin.

The loss of height from the beginning of the stall until regaining a normal level flight attitude is approx. 20 to 40 m (66-131 ft).

With the c/g in foremost position, the sailplane just stalls without dropping its nose or a wing.

Influence of water ballast

Apart from the higher mass in flight (i.e. a higher stalling speed), water ballast in the wing tanks has no aggravating influence on the stall characteristics.

With water ballast in the (optional) fin tank, the stall characteristics are like those found for aft c/g positions.

4.5.4 Approach

Normal approach speed with airbrakes fully extended, flaps set at "L" and wheel down is 100 km/h (54 kt, 62 mph) without water ballast, or 115 km/h (62 kt, 71 mph) at maximum permitted all-up mass.

In these configurations the L/D is approx. 5.7 : 1 for 15 m span and approx. 6.6 : 1 for 18 m span.

The airbrakes open smoothly - their effectiveness is very good.

There is no perceptible change of trim.

IMPORTANT NOTE:

For better aileron response and easier flap handling - especially in crosswinds - the flaps may also be set at "+1" for approach and landing.

The approach speeds quoted previously are then to be increased by at least 5 km/h (3 kt, 3 mph).

This approach technique with the flaps set at "+1" offers the pilot some reserve for the case of an approach over an obstacle being too short, as he may reset the flaps at "L", thus gaining temporarily some additional height (after touch-down the flaps are then set at "+1" or "0").

Side slip behaviour:

Side slips in 15 m configuration are a very effective landing aid and may be conducted in a straight line up to about 90 % of the rudder travel, resulting in a yaw angle of about 40° and a bank angle of about 25°.

Side slipping in 18 m configuration is less effective - keeping the flight path straight is only possible up to about 50 % of the rudder travel, resulting in a yaw angle of about 20 to 30° and a bank angle of about 10°.

Due to a small control force reversal a gentle amount of opposite pedal pressure is required to keep the rudder displaced. To return to level flight, apply (regardless of the span) normal opposite controls.

Side slipping causes the ASI to read less.

IMPORTANT NOTE:

With 18 m span and rudder displaced more than 50 % of its travel, a straight flight path cannot be maintained and the sailplane will turn in the direction of the displaced rudder.

Because of this behaviour, side slipping is not recommended - instead the effective airbrakes should be used.

WARNING:

Both the performance and the aerodynamic characteristics of the "Ventus-2c" are affected adversely by heavy rain or ice on the wing.

Be cautious when landing!

Increase the approach speed by at least 5 to 10 km/h (3-5 kt, 3-6 mph).

4.5.5 Landing

For off-field landings the undercarriage should always be extended, as the protection of the pilot is much better, especially from vertical impacts on landing.

Main wheel and tail wheel (or skid) should touch down simultaneously.

After touch-down the flaps may be set at "0" for improved aileron response during the landing run.

To avoid a long ground run, make sure that the sailplane touches down at minimum speed.

A touch-down at 90 km/h (49 kt, 56 mph) instead of 70 km/h (38 kt, 43 mph) means that the kinetic energy to be dissipated by braking is increased by a factor of 1.65 and therefore the ground run is lengthened considerably.

The landing run may be shortened by applying the wheel brake.

4.5.6 Flight with water ballast

If the maximum permitted all-up mass is to be reached, it is necessary to carry water ballast.

Wing ballast tanks

The water tanks are integral compartments in the nose section of the wing.

These tanks are to be filled with clear water only, through round openings (featuring a strainer) in the upper wing surface near the outer root rib of the in-board wing panels.

The tank opening is closed with a plugged-in filler cap having a 6 mm (0.24 in.) female thread for lifting and venting. Lifting the filler cap(s) is done with the aid of the tailplane rigging pin.

WARNING:

As the threaded hole in the filler cap also serves for venting the tank, it must always be kept open!

Each tank has a capacity of about 87 Liter (22.98 US Gal., 19.14 IMP Gal.).

Dumping water from full tanks takes about six minutes, but approx. 30 Liter (7.9 US Gal., 6.6 IMP Gal.) are discharged within the first minute.

When filling the tanks it must be ensured that the maximum permitted all-up mass is not exceeded - see loading chart on page 6.2.5.

The tank on either side must always be filled with the same amount of water to prevent lateral imbalance.

When taking off with partly full tanks, ensure that the wings are held level to allow the water to be equally distributed so that the wings are balanced.

Because of the additional mass in the wing panels the wing tip runner should continue running for as long as possible during the launch.

Water ballast is dumped through an opening on the lower side of the wing panels next to the root rib.

The dump valves are automatically hooked up to their actuating mechanism on the fuselage on rigging the wing panels (with the ballast control knob to be set at "CLOSED").

Thanks to baffles inside the ballast tanks there is no perceptible movement of the water ballast when flying with partly filled tanks.

When flying at maximum permitted all-up mass, the low speed and stall behaviour of the sailplane is slightly different from its behaviour without water ballast: The stall speeds are higher (see section 5.2.2) and for correcting the flight attitude larger control surface deflections are required. Furthermore more height is lost until a normal flight attitude is regained.

WARNING:

In the unlikely event of the tanks emptying unevenly or only one of them emptying (recognized by having to apply up to 50 % opposite aileron for a normal flight attitude), it is necessary to fly somewhat faster to take into account the higher mass and also to avoid stalling the sailplane.

During the landing run the heavier wing should be kept somewhat higher (if permitted by the terrain) so that it touches down at the lowest possible speed. This reduces the danger of the sailplane to veer off course.

Ventus-2c

Water ballast fin tank (option)

For optimum performance in circling flight, the forward travel of the center of gravity, caused by water ballast in the wing tanks, may be compensated by carrying water ballast in the fin tank.

For details concerning the quantities to be filled refer to page 6.2.7.

The water ballast tank is an integral compartment in the fin with a capacity of 6.0 Liter/kg (1.59 US Gal., 1.32 IMP Gal.). This tank is filled as follows - with the horizontal tailplane in place or removed:

Insert one end of a flexible plastic hose (outer diameter 8.0 mm/0.31 in.) into the tube (internal diameter 10.0 mm/0.39 in.) protruding from the rudder gap at the top of the fin on the port side. The other end of this hose is then connected to a suitable container which is to be filled with the required amount of clear water.

The tank has six (6) spill holes, all properly marked, on the starboard side of the fin, which indicate the water level - see accompanying sketch.

The venting of the tank is through the uppermost 6.0 Liter/kg hole (which always remains open - even with a full tank).

The ballast quantity to be filled depends on the water load in the wing tanks - see loading table on page 6.2.7.

Always tape closed one hole less than the load required, measured in kg/Liter.

If, for instance, a fin ballast load of 3.0 kg/Liter is required, only the lower two holes (1 and 2) are taped closed, any excessive water will then escape through the third spill hole, thus preventing any overloading.

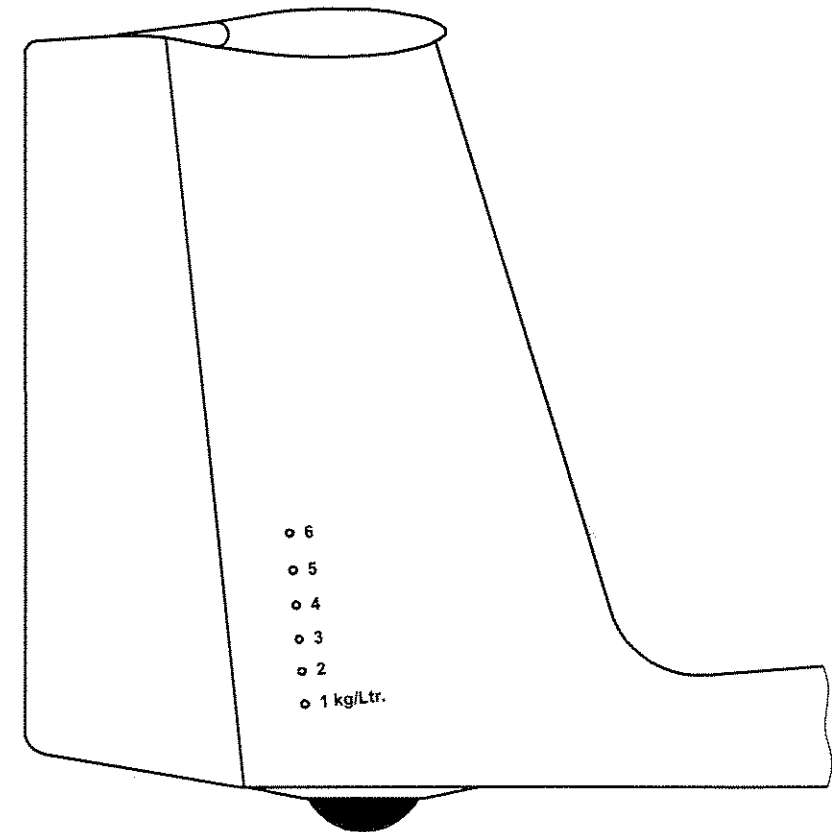

Water ballast is dumped from the fin tank through an opening on the lower side of the fuselage tail boom, adjacent to the rudder.

The fin tank dump valve is linked to the torsional drive for the valves in the wing panels, so that all three tanks are always opened simultaneously.

The time required to dump the ballast from a full fin tank is about 1.5 minutes, i.e. draining the fin tank always takes less time than discharging full wing tanks.

ctd. on page 4.5.6.5

GENERALWARNING:

1. On longer flights at air temperatures near 0° C (32° F), water ballast must be dumped in any case when reaching a temperature of 2° C (36° F).

CAUTION:

2. There is little point in loading much water ballast if the average rate of climb expected does not exceed 1.0 m/s (197 fpm). The same applies to flights in narrow thermals requiring steep angles of bank.
3. If possible, all water ballast is to be dumped before conducting an off-field landing.
4. Before the wing water tanks are filled, it must be checked (with dump valves unlocked) that both drain plugs open up equally. Leaking (dripping) valves are avoided by cleaning and greasing the plugs and their seats (with valves opened). Thereafter, with valves closed, the drain plugs are pulled home with the threaded tool used to attach the tailplane.

WARNING:

5. Never pressurize the tanks - for instance by filling them directly from a water hose - and always pour in clear water only.
6. On no account whatsoever must the sailplane ever be parked with full ballast tanks if there is the danger of them freezing up. Even in normal temperatures the parking period with full tanks should not exceed several days. For parking all water ballast is to be completely drained off with filler caps removed to allow the tanks to dry out.
7. Before the fin tank is filled, check that those spill holes not being taped closed are clear.

4.5.7 High altitude flight

When flying at high altitude it should be noted that true airspeed (TAS) increases versus indicated airspeed (IAS). This difference does not affect the structural integrity or load factors, but to avoid any risk of flutter, the following indicated values (IAS) must not be exceeded:

Altitude		V (IAS)			Altitude		V (IAS)		
m	ft	km/h	kt	mph	m	ft	km/h	kt	mph
0	0	270	146	168	6000	19685	220	119	137
1000	3281	270	146	168	7000	22966	208	112	129
2000	6562	270	146	168	8000	26247	196	106	122
3000	9843	257	139	160	9000	29528	185	100	115
4000	13123	244	132	152	10000	32808	164	89	102
5000	16404	232	125	144	12000	39370	150	81	93

Flying at temperatures below freezing point

When flying at temperatures below 0° C (32° F), as in wave or during the winter months, it is possible that the usual ease and smoothness of the control circuits is reduced.

It must therefore be ensured that all control elements are free from moisture so that there is no danger of them freezing solid. This applies especially to the airbrakes!

From experience gained to date it has been found beneficial to cover the mating surfaces of the airbrakes with "Vaseline" along their full length so that they cannot freeze solid. Furthermore the control surfaces should be moved frequently.

When flying with water ballast, observe the instructions given in section 4.5.6.

NOTE:

The polyester coating on this sailplane is known from many years experience to become very brittle at low temperature.

Particularly when flying in wave at altitudes in excess of about 6000 m (approx. 20000 ft), where temperatures of below -30° C (-22° F) may occur, the gel-coat, depending on its thickness and the stressing of the sailplane's components, is prone to cracking!

Initially, cracks will only appear in the polyester coating, however, with time and changing environment, cracks can reach the Epoxy/Carbon cloth matrix.

Cracking is obviously enhanced by steep descents from high altitudes at associated very low temperatures.

WARNING:

Therefore, for the preservation of a proper surface finish free from cracking, the manufacturer strongly advises against high altitude flights with associated temperatures of clearly below -20° C (-4° F)!

A steep descent with the airbrakes extended should only be conducted in case of emergency (instead of the airbrakes, the undercarriage may also be extended to increase the rate of sink).

4.5.8 Flight in rain

When flying the sailplane with a wet surface or in rain, the size of the water drops adhering to the wing causes a deterioration of its flight performance which cannot be expressed in numerical values due to the difficulties involved with such measurements. Often the air mass containing the moisture is also descending so that - compared with a wet sailplane in calm air - the sink rates encountered are higher.

Flight tests in rain, conducted by the manufacturer, did not reveal any significant differences in the stalling behaviour or stalling speeds.

It cannot be excluded, however, that excessive alterations of the airfoil (as caused by snow, ice or heavy rain) result in higher minimum speeds.

Approach in rain: See page 4.5.4.

4.5.9 Aerobatics (only permissible in 15 m configuration and without water ballast)

The following aerobatic maneuvers are permitted:

- (a) Inside loops
- (b) Stalled turns
- (c) Lazy eight

Inside loop

Enter the maneuver at a speed of 200 km/h (108 kt, 124 mph) with flaps set at "-2".

At the top of the loop select flap setting "0".

Speed during recovery from the maneuver: 180 to 200 km/h (97-108 kt, 112-124 mph), flaps at "-2".

Stalled turn

Enter the maneuver at a speed of between 190 and 200 km/h (103-108 kt, 118-124 mph) with flaps set at "-2".

Whilst climbing vertically let the wing which will be on the inside of the turn drag and then, at about 140 km/h (76 kt, 87 mph), apply rudder in the direction of the dragging wing in order to prevent a distorted maneuver.

Lazy eight

Enter the maneuver at a speed of between 190 and 200 km/h (103-108 kt, 118-124 mph) with flaps set at "-2".

After pulling up in a 45° climb, enter a turn at about 140 km/h (76 kt, 87 mph).

The recovery speed is between 180 and 200 km/h (97-108 kt, 112-124 mph).

Section 5

- 5. Performance
- 5.1 Introduction
- 5.2 LBA-approved data
 - 5.2.1 Airspeed indicator system calibration
 - 5.2.2 Stall speeds
 - 5.2.3 (reserved)
 - 5.2.4 Additional information
- 5.3 Additional information -
LBA-approval not required
 - 5.3.1 Demonstrated crosswind performance
 - 5.3.2 Flight polar

5.1 Introduction

This section provides LBA-approved data for airspeed calibration, stall speeds and non-approved additional information.

The data in the charts has been computed from actual flight tests with a sailplane in good condition and using average piloting techniques.

5.2 LBA-approved data

5.2.1 Airspeed indicator system calibration

Errors in indicated airspeed (IAS) caused by Pitot/Static pressure errors may be read off from the calibration chart shown below. This chart is applicable to free flight with flaps set at "-1".

PITOT pressure source : Near top of fin (lower port)

STATIC pressure ports : Fuselage tail boom, 80 cm (31.5 in.) forward of base of fin and 15 cm (5.9 in.) below main spar cut-out

All airspeeds shown in this manual are indicated airspeeds (IAS) as registered by the airspeed indicator.

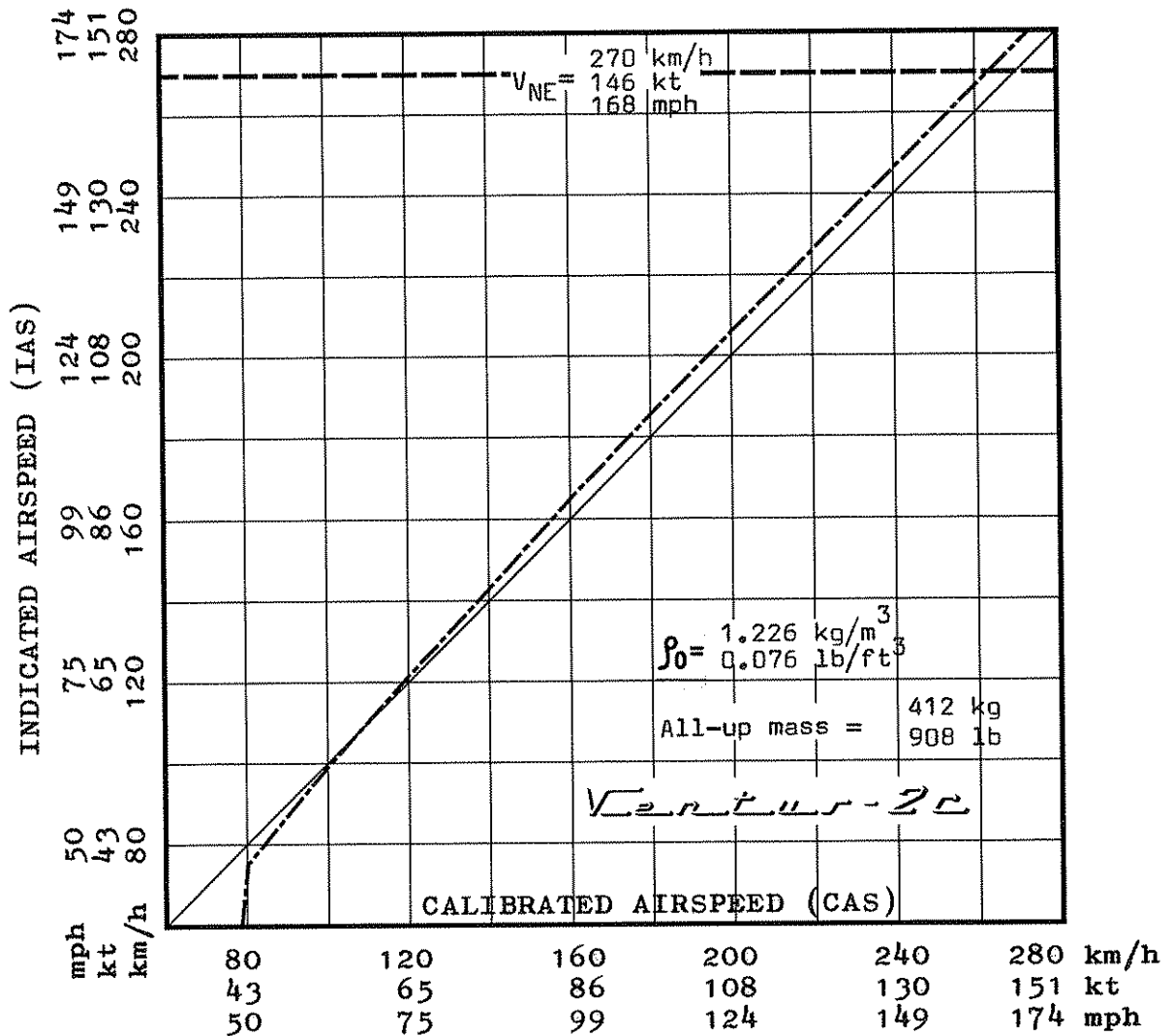

5.2.2 Stall speeds

The following stall speeds (IAS) at various flap settings were determined in straight and level flight:

Wing span		15 m		18 m	
All-up mass approx.		370 kg 816 lb	525 kg 1157 lb	500 kg 1102 lb	525 kg 1157 lb
C/G position aft of datum		250 mm 9.84 in.	380 mm 14.96 in.	250 mm 9.84 in.	380 mm 14.96 in.
<u>Stall speed, airbrakes closed</u>					
flaps at "+2"	km/h	66	69 ± 5	80 - 77	65 ± 5
	kt	36	37 ± 3	43 - 42	35 ± 3
	mph	41	43 ± 3	50 - 48	40 ± 3
flaps at "0"	km/h	74	75 ± 5	82 - 80	70 ± 5
	kt	40	40 ± 3	44 - 43	38 ± 3
	mph	46	47 ± 3	51 - 50	43 ± 3
flaps at "S1"	km/h	82	81 ± 5	92	75 ± 5
	kt	44	44 ± 3	50	40 ± 3
	mph	51	50 ± 3	57	47 ± 3
<u>airbrakes extended</u>					
flaps at "L"	km/h	76	75 ± 5	82 - 77	70 ± 5
	kt	41	40 ± 3	44 - 42	38 ± 3
	mph	47	47 ± 3	51 - 48	43 ± 3

Airspeed indication oscillating with rearward c/g positions

The loss of height from the beginning of the stall until regaining a normal level flight attitude is up to 40 m (131 ft).

Ventus-2c

FLIGHT MANUAL

5.2.3 - INTENTIONALLY LEFT BLANK -

Ventus-2c

FLIGHT MANUAL

5.2.4 Additional information

N o n e

5.3 Non-LBA-approved additional information

5.3.1 Demonstrated crosswind performance

The maximum crosswind velocity, at which take-offs and landings have been demonstrated, is

20 km/h (11 kt).

5.3.2 Flight polar

All values shown below refer to MSL.

Wing span	15 m	18 m	18 m
All-up mass	395 kg 871 lb	340 kg 750 lb	423 kg 933 lb
Wing loading	40.7 kg/m ² 8.3 lb/ft ²	30.9 kg/m ² 6.3 lb/ft ²	38.5 kg/m ² 7.9 lb/ft ²
Minimum rate of sink	0.59 m/s 116 fpm	0.45 m/s 89 fpm	0.50 m/s 98 fpm
at a speed of	80 km/h 43 kt 50 mph	72 km/h 39 kt 45 mph	80 km/h 43 kt 50 mph
Best L/D approx.			
at a speed of	100-110 km/h 54- 59 kt 62- 68 kt	80- 90 km/h 43- 49 kt 50- 56 kt	90-100 km/h 49- 54 kt 56- 62 mph

A speed polar diagram is shown on page 5.3.2.2

Ventus-2c

43	50	56	62	68	75	81	87	93	99	106	112	118	124	mph
38	43	49	54	59	65	70	76	81	86	92	97	103	108	kt
70	80	90	100	110	120	130	140	150	160	170	180	190	200	km/h

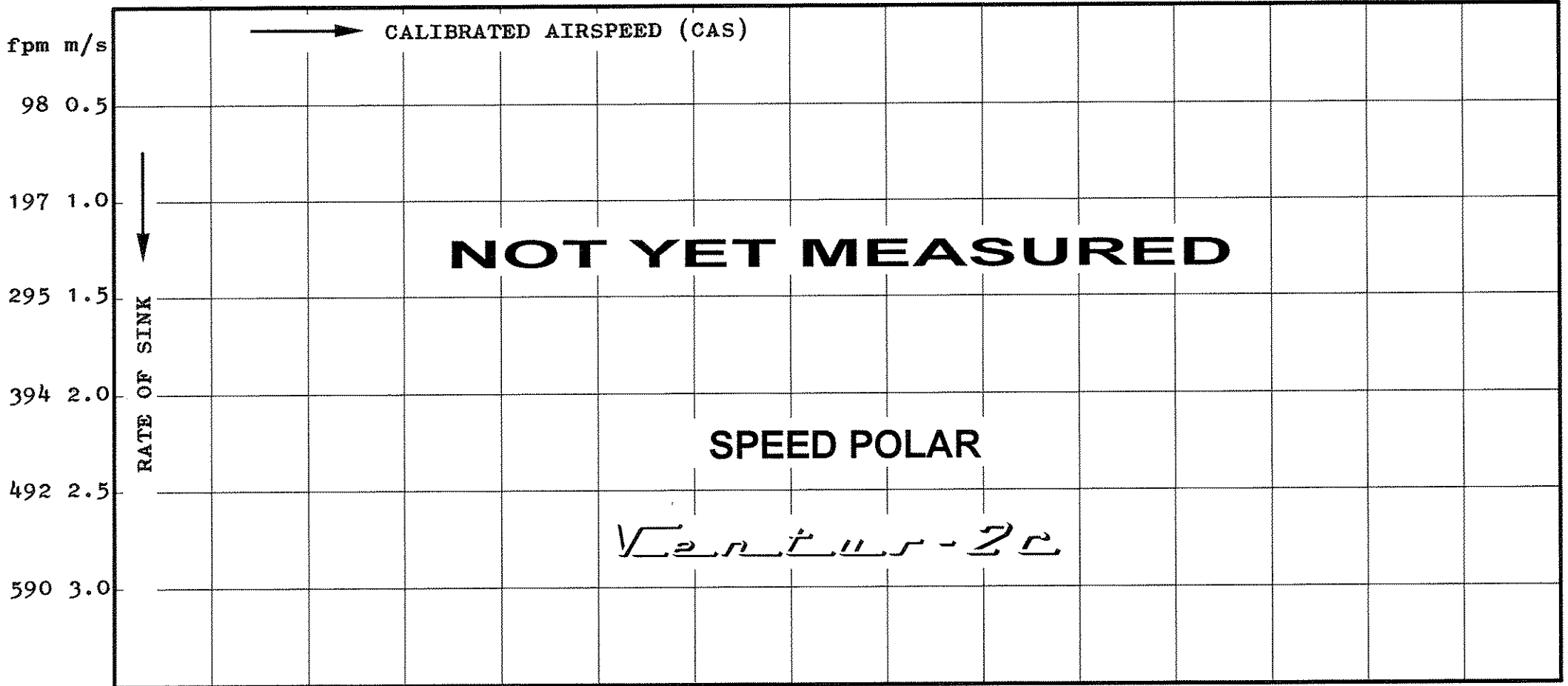

Section 6

6. Weight (mass) and balance

6.1 Introduction

6.2 Weight (mass) and balance record
and permitted payload range.

Determination of:

- Water ballast in wing tanks

- Water ballast in fin tank

6.1 Introduction

This section contains the seat load range within which the sailplane may be safely operated.

Procedures for weighing the sailplane and the calculation method for establishing the permitted seat load range and a comprehensive list of all equipment available are contained in the Maintenance Manual.

The equipment actually installed during the last weighing of the sailplane is shown in the "Equipment List" to which page 6.2.3 refers to.

6.2 Weight and balance record / Permitted seat load range

The following weight and balance log sheet (page 6.2.3) shows the maximum and minimum load on the seat.

It is established with the aid of the last valid weighing report - the required data and diagrams are found in the Maintenance Manual.

The weight and balance log sheet is only applicable for this particular sailplane, the serial number of which is shown on the title page.

A seat load of less than the required minimum is to be compensated by ballast - there are two methods:

1. By attaching ballast (lead or sand cushion) firmly to the lap belt mounting brackets.
2. By installing ballast (by means of lead plates) into the fuselage nose.

For further information refer to page 6.2.2.

Altering the minimum seat load by trim ballast weights

A trim ballast mounting provision is provided in the fuselage nose forward of the rudder pedal assembly.

Optional trim ballast weights

The ballast mounting provision holds up to three (3) lead plates with a weight of 2.1 kg (4.6 lb) each and allows a reduction of the placarded minimum seat load as shown in the following table:

Difference as compared with placarded minimum:	Number of lead plates required:
up to 5 kg (11 lb) less	1
up to 10 kg (22 lb) less	2
up to 15 kg (33 lb) less	3

Lever arm of trim ballast plates:

1740 mm (68.50 in.) ahead of datum

WEIGHT AND BALANCE LOG SHEET (loading chart)

for Ser.No.:

Date of weighing					
Empty mass (kg)	18 m				
	15 m				
Equipment list dated					
Empty mass c/g position (mm) aft of datum (18 m)					
Seat load (pilot incl. parachute)	Max. (kg)*				
	Min. (kg)				
Max. useful load in fuselage (kg) incl. ballast in fin tank					
Inspector Signature Stamp					

* Note: The maximum load on the seat (pilot with parachute) must not exceed 110 kg (242.5 lb).

For the determination of water ballast in the wing tanks refer to page 6.2.5.

For the determination of water ballast in the fin tank refer to page 6.2.6 and 6.2.7.

6.2.4 - INTENTIONALLY LEFT BLANK -

Ventus-2c

FLIGHT MANUAL

Maximum water ballast load

Wing span	:	15 m	18 m
Maximum all-up mass incl. water ballast	:	525 kg 1157 lb	
C/G position of water ballast in wing tanks (aft of datum)	:	179 mm 7.05 in.	
Total wing tank capacity	:	174 Liter 45.97 US Gal 38.28 IMP Gal	

Table of water ballast loads at various empty weights and seat loads for 525 kg / 1157 lb all-up mass:

Empty mass *	LOAD ON THE SEAT (kg/lb)															
	kg	lb	kg	lb	kg	lb	kg	lb	kg	lb	kg	lb				
kg	lb	70	154	80	176	90	198	100	220	110	243					
260	573	174	46.0	38.3	174	46.0	38.3	174	46.0	38.3	165	43.6	36.3	155	40.9	34.1
270	595	174	46.0	38.3	174	46.0	38.3	165	43.6	36.3	155	40.9	34.1	145	38.3	31.9
280	617	174	46.0	38.3	165	43.6	36.3	155	40.9	34.1	145	38.3	31.9	135	35.7	29.7
290	639	165	43.6	36.3	155	40.9	34.1	145	38.3	31.9	135	35.7	29.7	125	33.0	27.5
		Liter	US Gal	IMP Gal	Liter	US Gal	IMP Gal	Liter	US Gal	IMP Gal	Liter	US Gal	IMP Gal	Liter	US Gal	IMP Gal
WATER BALLAST IN WING TANKS																

NOTE:

When determining the max. permitted wing water ballast load, allowance must be made for water ballast in the fin tank (see page 6.2.6 and 6.2.7), i.e. this load must be added to the empty mass shown in the above table.

* Empty mass = empty mass as per page 6.2.3 + fin ballast

Water ballast loads in (optional) fin tank

WARNING: Water ballast in the fin tank may only be used to compensate the nose-heavy moment of water ballast carried in the wing tanks!

The determination of the ballast quantity carried in the fin tank (m_{FT}) is done with the aid of the diagram shown on page 6.2.7.

Notes concerning the use of the fin tank are given on page 4.5.6.3.

When determining the quantity of water ballast for the fin tank, bear in mind that the maximum permitted useful load in the fuselage (see weight and balance log sheet on page 6.2.3) must not be exceeded - check as follows:

m_P	=	Seat load (pilot with parachute)
m_{FT}	=	Water ballast load in fin tank
m_{WT}	=	Water ballast load in wing tanks
$m_P + m_{FT}$	=	less or equal to maximum permitted useful load in fuselage (see page 6.2.3)

Example:

Assumed ballast load in wing tanks : 80.0 kg/Liter

Permissible ballast load (fill only full Liters) in fin tank according to diagram on page 6.2.7 : 3.0 kg/Liter

Lever arm of water ballast in fin tank

4275 mm (168.31 in.) aft of datum

Fin tank capacity :

6.00 Liter/kg
1.59 US Gal.
1.32 IMP Gal.

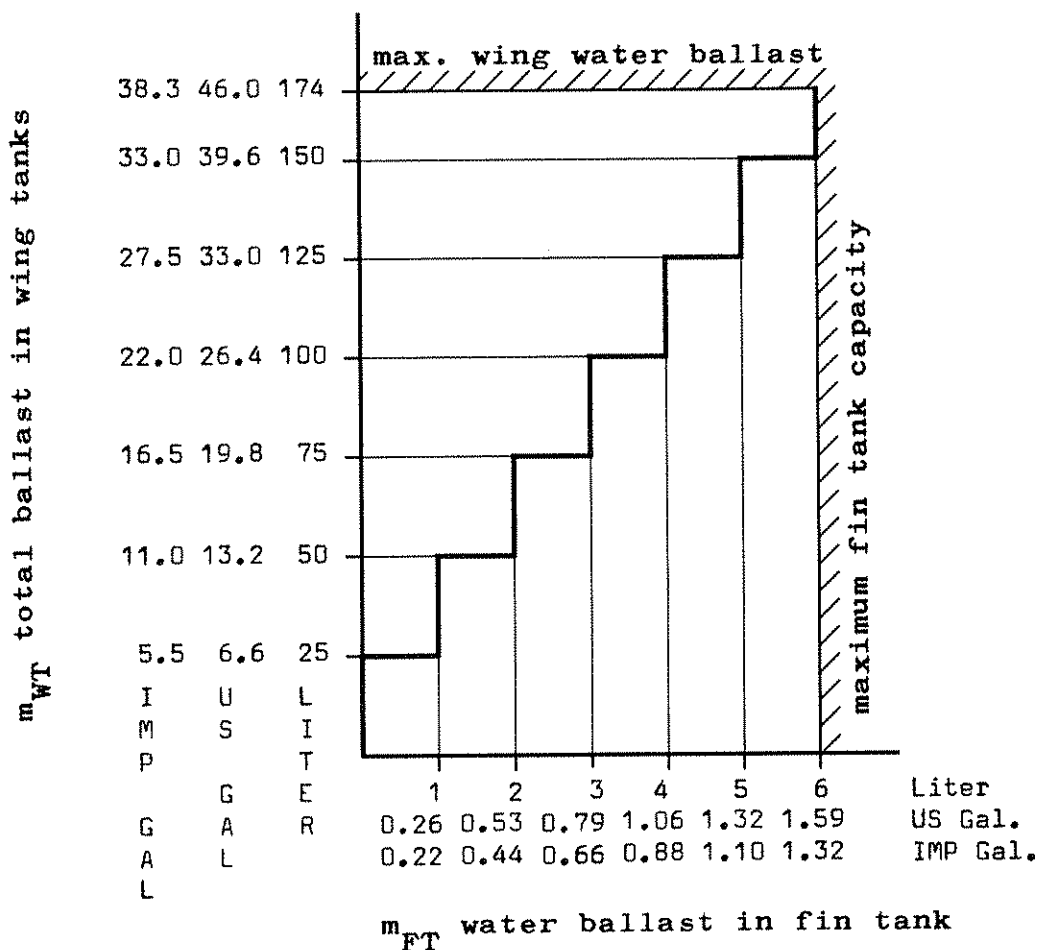

Note:

Always full Liters are to be filled.
Where value jumps, either the higher or the lower amount of ballast may be used.

Section 7

- 7. Description of the sailplane and its systems
 - 7.1 Introduction
 - 7.2 Cockpit description
 - 7.3 Instrument panel
 - 7.4 Undercarriage
 - 7.5 Seat and restraint system
 - 7.6 Static pressure and Pitot pressure system
 - 7.7 Airbrake system
 - 7.8 Baggage compartment
 - 7.9 Water ballast system(s)
 - 7.10 (reserved)
 - 7.11 (reserved)
 - 7.12 Electrical system
 - 7.13 Miscellaneous equipment
(removable ballast, oxygen, ELT etc.)

7.1 Introduction

This section provides a description of the sailplane including the operation of its systems.

Refer to section 9 ("Supplements") for details of optional systems and equipment.

For further descriptions of components and systems of the sailplane refer to section 1 of the Maintenance Manual.

7.2 Cockpit description

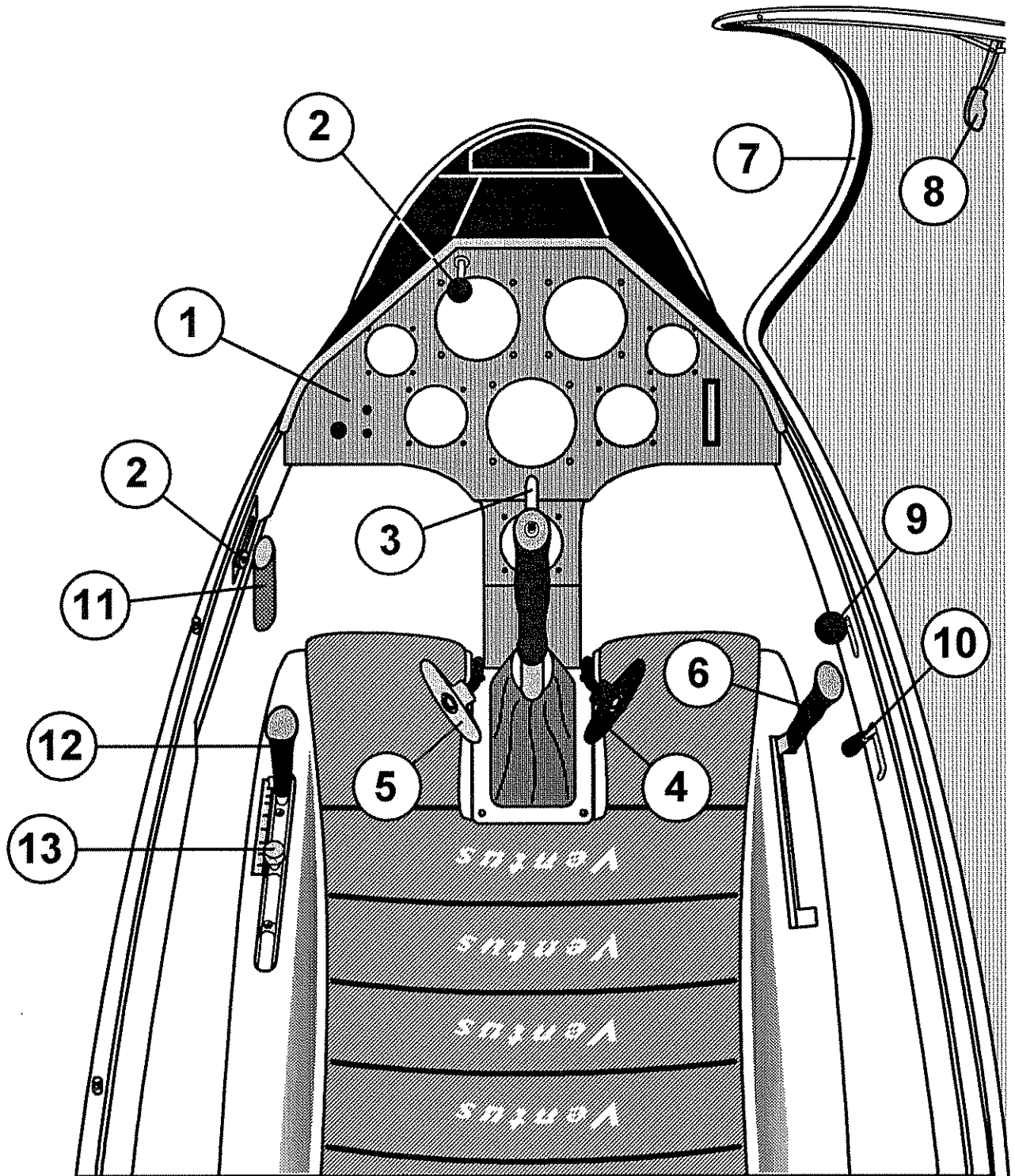

All instruments and control elements are within easy reach of the pilot.

1

Tilt-up instrument panel

Four quick-fasteners or screws secure the panel cover to the instrument panel and to its tubular mounting frame.

Panel rises under light pressure with the canopy opened.

2

Ventilator control

S/N 1 through 12:

Small black knob (gradually and infinitely adjustable) on the instrument panel.

S/N 13 and up:

Knurled gold-coloured knob on the cockpit inner skin on the left in the front.

Ventilator closed - knob in backward position

Ventilator opened - knob in forward position

Additionally the sliding window or the airscoop in the window may be opened for ventilation.

3

Wheel brake

The wheel brake lever is mounted on the control stick.

4

Rudder pedal adjustment

Black T-shaped handle on the right at the base of the instrument panel/console.

Forward adjustment : Release locking device by pulling the handle, push pedals to desired position with the heels and let them engage.

Backward adjustment: Pull handle back until pedals have reached the desired position. Forward pressure with the heels (not the toes) engages pedals in nearest notch with an audible click.

The rudder pedals may be adjusted on the ground or in the air.

5

Control handle for tow release mechanism(s)

Yellow T-shaped handle on the left at the base of the instrument panel/console, actuating the nose and/or the c/g tow release (whichever is installed).

The aerotow rope / winch cable is released by pulling this handle.

6

Undercarriage

Retracting : Disengage black handle on the right at the seat pan mounting flange, pull it back and lock in rear recess.

Extending : Disengage handle, push it forward and lock in front recess.

7

Canopy

The one-piece plexiglass canopy hinges sideways on flush fittings.

Take care that the cable restraining the open canopy is properly hooked up.

8

Canopy locking and jettisoning lever

Red lever on the canopy frame on the left.

Forward position : Canopy locked

To open or jettison the canopy, swing lever back (approx. 90°) up to its stop and raise canopy.

9

Canopy detachment

Sliding black knob on the cockpit inner skin on the right.

Forward position : Canopy locked

To remove the canopy, pull knob backwards.

10

Control knob for dumping water ballast from wing tanks and (optional) fin tank

Black knob in the middle of the cockpit inner skin on the right.

Forward position : Valves closed

Rearward position: Valves opened

The knob is locked in the extreme positions by swinging it downwards into the recess.

11

Airbrake lever

Blue lever on the left hand side of the cockpit.

Forward position : Closed and locked

Pulled back approx.
40 mm (1.6 in.) : Unlocked

Pulled fully back : Fully extended

12

Flap lever

Black lever on the seat pan mounting flange on the left. Swing lever slightly inwards, move to desired setting and let it engage in appropriate notch.

Forward position : High speed range

Rearward position : Low speed range

13

Elevator trim

Knurled green knob on the left, mounted on the flap actuating tube.

The spring-loaded trim is infinitely adjustable by freeing the knurled knob, sliding it to the desired position and tightening the knob again.

Forward position : Nose heavy

Rearward position : Tail heavy

A neutral position of the trim at flap setting "0" is shown at the recess by means of a green marking.

14

Parachute rip cord attachment (not illustr.)

Red ring, situated at the front of the fuselage steel tube center frame on the left.

15

Seat back (not illustrated)

This is horizontally adjustable on the ground (thanks to two notches in the seat pan) to match the pilot's size.

Additionally it is resettable in flight (for an upright or reclining position) with the aid of a black knob situated on the lower side of the cockpit inner skin on the right.

S/N 1 through 7, S/N 17 and up:

More upright : Unlock knob (by moving it downwards), push it forwards and let it engage in notch nearest to desired seat back position

More reclining : Unlock knob, slide it back and let knob engage

S/N 8 through 16

More upright : Unlock knob (by moving it downwards), pull it back and let it engage in notch nearest to desired seat back position

More reclining : Unlock knob, slide it forwards and let knob engage

7.3 Instrument panel

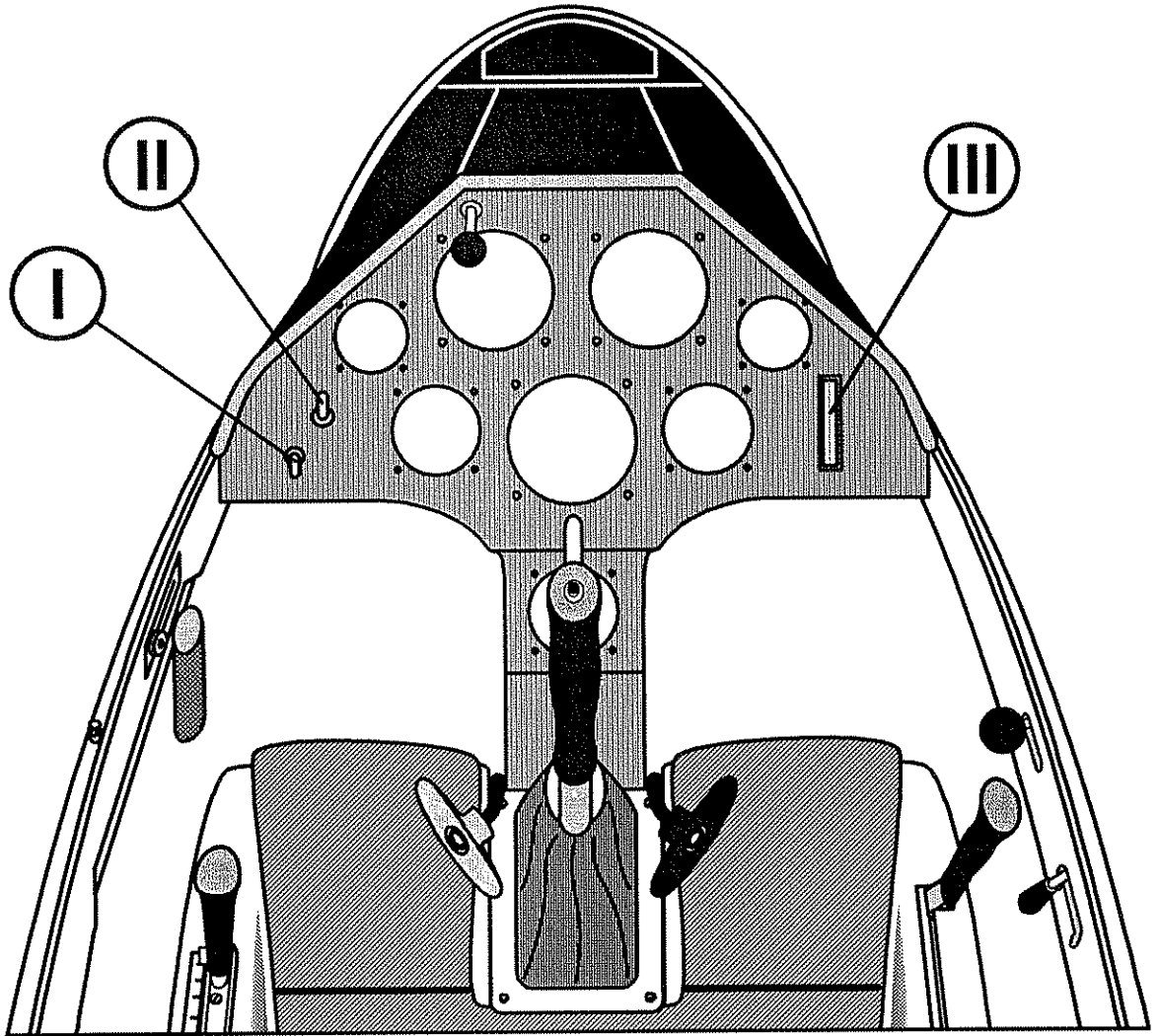

For a description of components No. I through III refer to page 7.3.2.

A description of the instrumentation is not deemed necessary.

I

Main switch

Panel-mounted "ON/OFF" switch

UP	=	ON
DOWN	=	OFF

II

(reserved)

III

Outside air temperature indicator

When carrying water ballast, the outside air temperature (OAT) must not drop below 2° C (36° F).

7.4 Undercarriage

The main wheel of the sailplane is retractable and features a mechanical drum brake.

Instead of the standard rubber tail skid a pneumatic wheel is installed on request.

The extension/retraction process of the main wheel is described on page 7.2.3.

For a technical description of the retractable undercarriage including wheel brake refer to section 1 of the Maintenance Manual.

7.5 Seat and restraint system

The seat pan is bolted to mounting flanges provided on either side of the cockpit.

A seat back with integrated head rest, adjustable in flight for an upright or reclining position, is standard.

The lap straps are anchored to the seat pan, the shoulder straps are attached to the front wing suspension tube.

A list of approved restraint systems is found in section 7.1 of the Maintenance Manual.

7.6 Static pressure and Pitot pressure systemStatic pressure sources

- a) Static pressure ports are on either side of the fuselage tail boom, 0.8 m/31.5 in. forward of the base of the fin (in the horizontal plane) and 0.15 m/5.9 in. below the fuselage-to-wing fillet (to be used for airspeed indicator etc.).
- b) On request a special static pressure probe can be installed near the top of the fin (for further instruments, except ASI).

Pitot pressure source

The Pitot pressure head is near the top of the fin (to be used for airspeed indicator and other instruments).

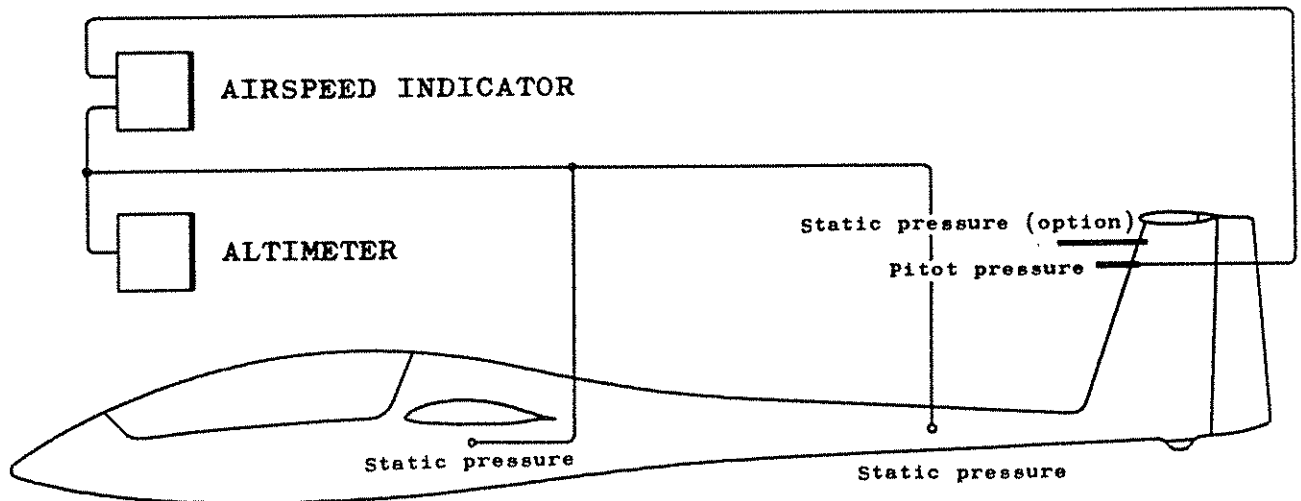

7.7 Airbrake system

Double-panel Schempp-Hirth type airbrakes are employed on the upper surface of the inboard wing panels. They open smoothly and are very effective - there is no perceptible change in trim.

When unlocked, the airbrakes might get slightly sucked out by their spring-loaded cover strips, which in turn may then oscillate within their travel, causing some rattling and/or banging. This is immediately stopped by further extending the airbrakes. The control of the sailplane is not affected.

With airbrakes extended, the indicated stalling speed is about 5 to 10 km/h higher (3-5 kt, 3-6 mph) - see page 5.2.2.

A view of the airbrake system is found in the Maintenance Manual.

7.8 Baggage compartment

Although an enclosed baggage compartment is not provided, soft objects (like jackets etc.) may be deposited on the removable panel (covering the control linkage) behind the main spar stubs - the head rest obstructs the access opening to a large extent.

Such baggage, however, must be taken into account when determining the permissible load on the seat.

7.9 Water ballast system(s)

Wing tanks

A metal rod connects the operating knob in the cockpit to a torsional drive (in the fuselage center) which, on rigging the inbd. wing panels, automatically hooks up to torque tubes actuating the wing tank dump valves. These tubes are rotated to their "closed" position by spring force. The operating knob in the cockpit runs in a gate and can be locked in the extreme positions.

For notes on how to fly with water ballast refer to section 4.5.6.

For water ballast loading tables refer to page 6.2.5 and the following.

A view of the wing water ballast system is provided on page 7.9.2.

Fin tank (option)

A steel cable connects the torsional drive in the fuselage center to the dump valve of the fin tank - hence the knob in the cockpit controls all tanks.

A description on how to use the fin tank is found on page 4.5.6.3 and the following.

A water ballast loading table is provided on page 6.2.6 and the following.

For a view of the water ballast system in the fin refer to page 7.9.3.

Ventus-2c

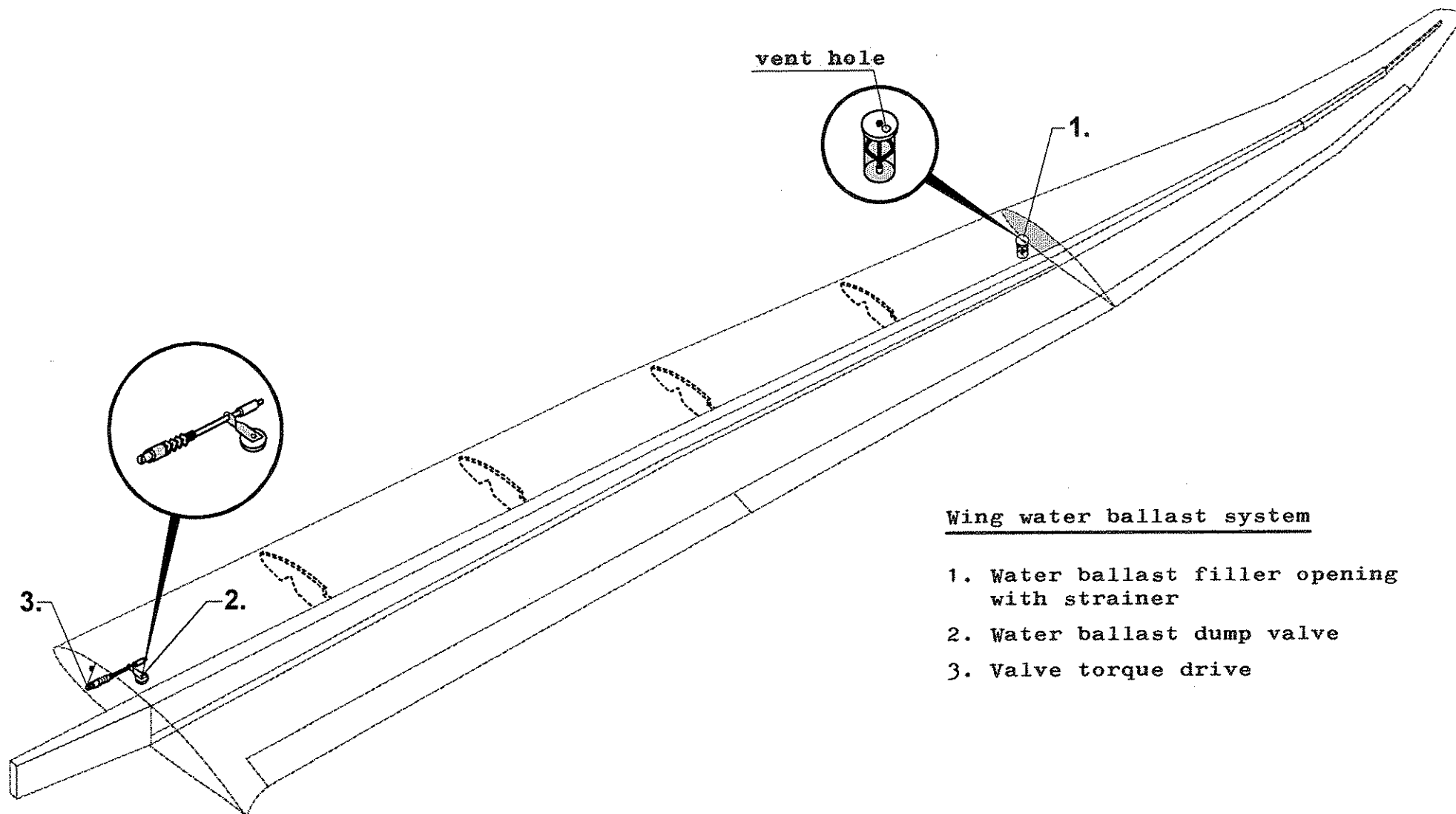

Wing water ballast system

1. Water ballast filler opening with strainer
2. Water ballast dump valve
3. Valve torque drive

Ventus-2c

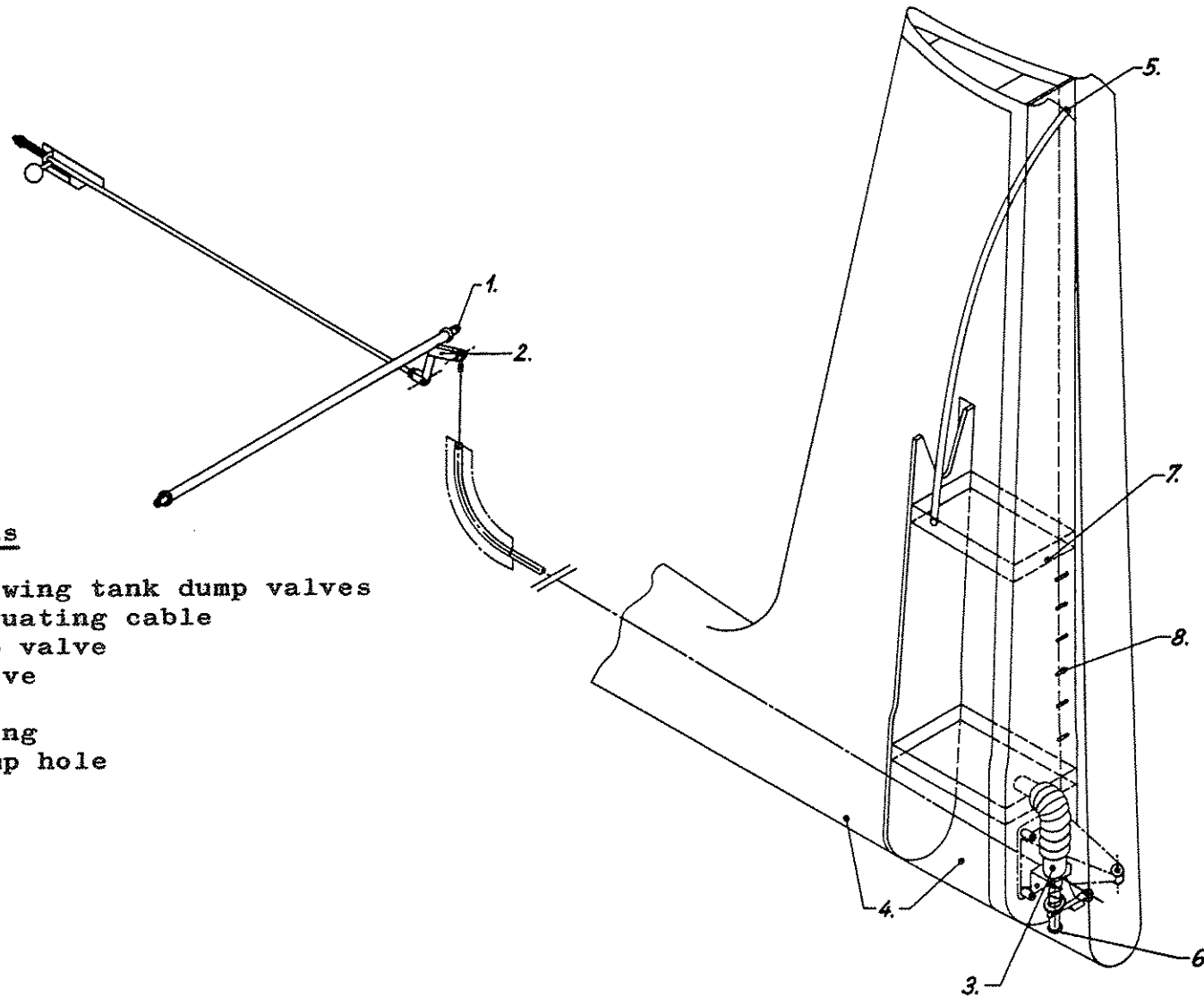
Water ballast systems

1. Torque drive for wing tank dump valves
2. Connection of actuating cable for fin tank dump valve
3. Fin tank dump valve
4. Vent hole
5. Filler tube opening
6. Water ballast dump hole
7. Drain hole
8. Spill holes

November 1995
Revision -

7.9.3

7.10 - INTENTIONALLY LEFT BLANK -

7.11 - INTENTIONALLY LEFT BLANK -

7.12 Electrical systemGliding avionics

- See also wiring diagram on page 7.12.2.

The wiring of the gliding avionics is shown on the next page and must comply with the manufacturer's instructions for the relevant equipment.

Power to operate the avionics is provided by one or more batteries located

- at the top of the fin and/or
- next to the main wheel housing and/or
- at the base of the instrument panel.

A main switch controls the power source(s).

Ventus-2c

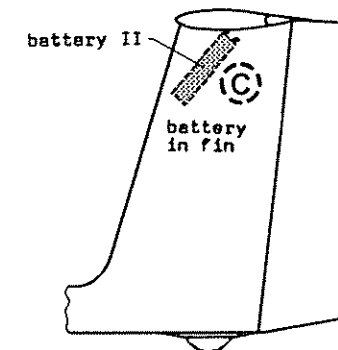
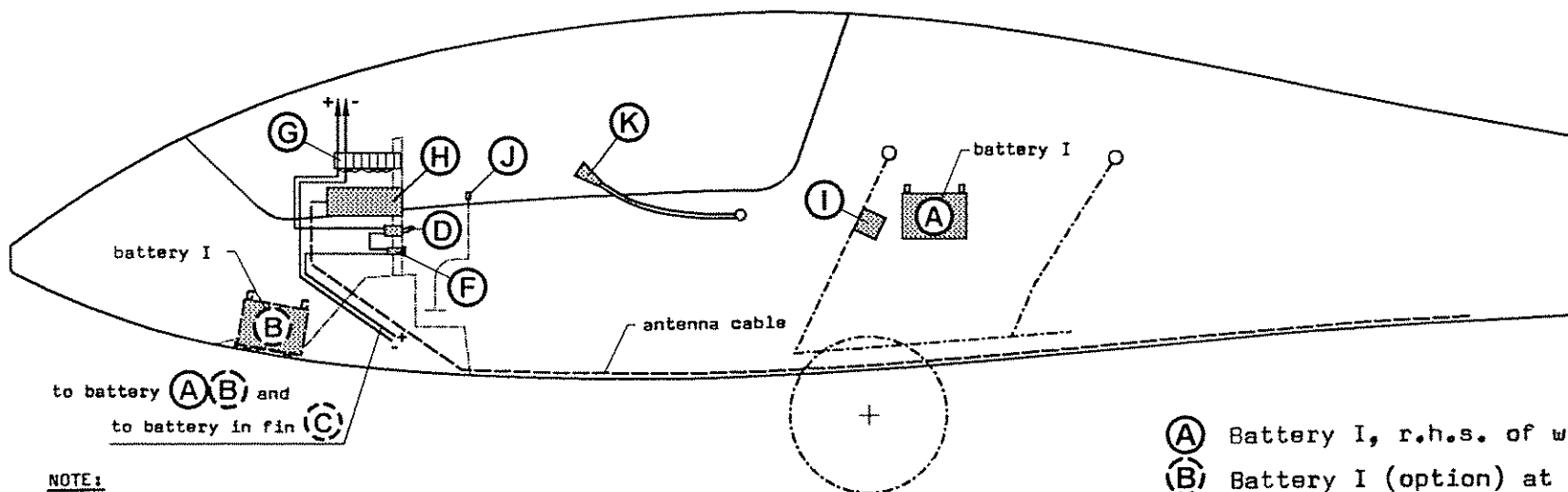

to battery (A)(B) and
to battery in fin (C)

NOTE:
VHF-Transceiver and other additional equipment to be wired in compliance with the manufacturer's instructions and to be fused individually.

- (A) Battery I, r.h.s. of wheel box, 12 V/7.2 Ah
- (B) Battery I (option) at panel base, 12V/7.2 Ah
- (C) Battery II (option) in fin, 12 V/4.0 Ah (up to S/N 42)
12 V/7.0 Ah (S/N 43 and up)
- (D) Main switch
- (E) Battery selector switch I/II
- (F) Fuse 4 A (6.3 A)
- (G) Bus bar (e.g. AMP Terminal)
- (H) VHF-Transceiver
- (I) Speaker
- (J) PTT button
- (K) Boom mike

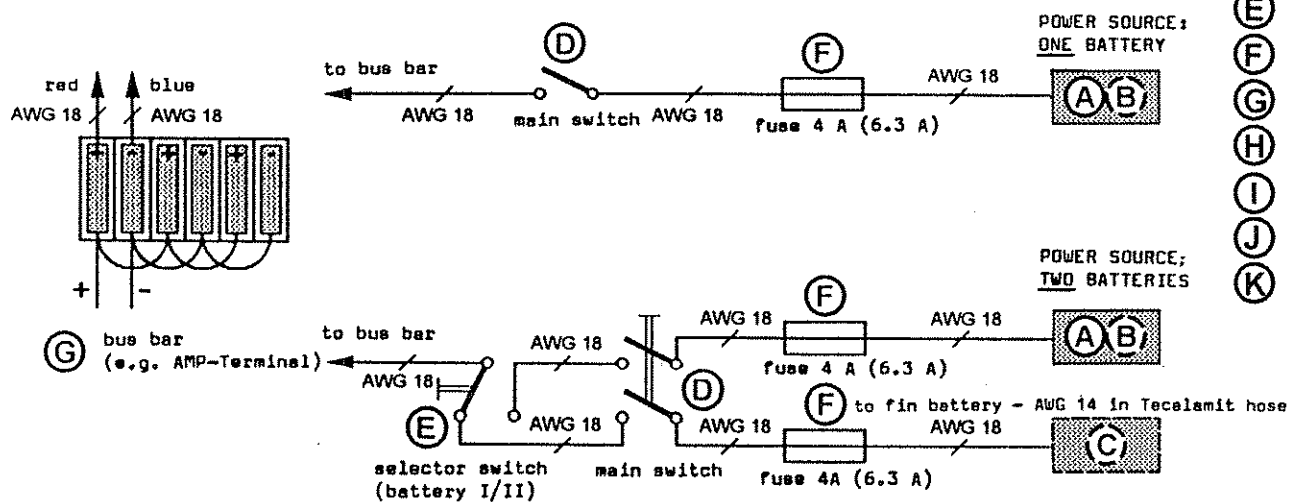

- ELECTRICAL SYSTEM - AVIONIC -
S08 RE 810

7.13 Miscellaneous equipmentRemovable ballast (option)

A mounting provision for removable ballast (trim ballast weights) is provided in the fuselage nose forward of the rudder pedal assembly.

The trim ballast weights (lead plates) are attached to the GFRP frame by means of a wing bolt.

For information on how to alter the minimum seat load refer to section 6.2.

Oxygen system

Attachment points for the mounting brackets of an oxygen bottle are provided on the rear wing suspension tube (for the neck) and further aft on the fuselage skin (for the body).

Drawings for the installation of an oxygen system may be obtained from Schempp-Hirth.

NOTE: After installation of an oxygen system it is necessary to re-establish the empty mass c/g position of the sailplane concerned. This is to ensure that the center of gravity is still within the permitted range.

A list of oxygen regulators, currently approved by the Luftfahrt Bundesamt (LBA), is found in the Maintenance Manual.

ELT-installation

The installation of an Emergency Locator Transmitter is possible in the following places and must comply with the appropriate instructions provided by Schempp-Hirth:

- In the cockpit below the canopy frame
on the right hand side in the rear

or

- on the seat pan mounting flange
on the right hand side in the rear

- In the region of the fuselage center frame
next to the main wheel housing

- On a panel above the main spar stubs

A list of ELTs, currently approved by the LBA, is found in the Maintenance Manual.

Section 8

- 8. Sailplane handling, care and maintenance
 - 8.1 Introduction
 - 8.2 Sailplane inspection periods
 - 8.3 Sailplane alterations or repairs
 - 8.4 Ground handling / road transport
 - 8.5 Cleaning and care

8.1 Introduction

This section contains manufacturer's recommended procedures for proper ground handling and servicing of the sailplane.

It also identifies certain inspection and maintenance requirements which must be followed if the sailplane is to retain that "new plane" performance and dependability.

CAUTION:

It is wise to follow a planned schedule of lubrication and preventative maintenance based on climate and flying conditions encountered - see section 3.2 of the Maintenance Manual.

8.2 Sailplane inspection periods

For details concerning the maintenance of the sailplane refer to its Maintenance Manual.

Airframe maintenance

Under normal operating conditions no airframe maintenance work is required between the annual surveys, except for the routine greasing of the spigots and ball bearings of the wing and tailplane attachment fittings.

Should the control system become heavy to operate, lubricate those places in the fuselage and in the wing panels where plain bearings are used (under-carriage, flap and airbrake actuating linkage).

Cleaning and greasing the wheel(s) and the tow release(s) depends on the accumulation of dirt.

Rudder cables

After every 200 flying hours and at every annual survey, the rudder cables are to be inspected at the point where they feed through the S-shaped guides in the pedals, especially at the point of maximum pedal adjustment.

If the rudder cables are damaged, worn or corroded, they must be replaced.

It is permissible for individual strands of the cables to be worn up to 25 %.

8.3 Sailplane alterations or repairs

Alterations

Alterations on the approved model, which might affect its airworthiness, must be reported to the responsible airworthiness authorities *p r i o r* to their accomplishment.

The authorities will then determine whether and to what extent a "supplemental type approval" is to be conducted.

In any case, the manufacturer's opinion about the alteration(s) must be obtained.

This ensures that the airworthiness does not become adversely affected and/or enables the sailplane owner/operator to demonstrate at any time that the aircraft concerned complies with an LBA-approved version.

Amendments of the LBA-approved sections of the Flight and/or Maintenance Manual must in any case be approved by the Luftfahrt Bundesamt (LBA).

Repairs

Before every take-off and especially after the sailplane has not been used for a while, it should be checked on the ground as shown in section 4.3.

Check for any sign of a change in the condition of the sailplane, such as cracks in the surface, holes, delamination in the CFRP/GFRP structure etc.

If there is any uncertainty whatsoever regarding the significance of damage discovered, the sailplane should always be inspected by a CFRP/GFRP expert.

There is no objection to minor damage - which does not affect the airworthiness in any way - being repaired on site.

A definition of such damage is included in the "Repair Instructions" which are found in the appendix to the "Ventus-2c" Maintenance Manual.

Major repairs may only be conducted by a certified repair station having an appropriate authorization.

8.4 Ground handling / road transporta) Towing/ Pushing

When towing the sailplane behind a car, a tail dolly should always be used to avoid unnecessary tailplane vibration on the fittings - especially in tight turns.

When pushing the sailplane by hand, it should not be pushed at its wing tips, but as near to the fuselage as possible.

b) Hangaring

The sailplane should always be hangared or kept in well ventilated conditions. If it is kept in a closed trailer, there must be adequate ventilation.

The water ballast tanks must always be left completely empty.

The sailplane must never be subjected to loads whilst not in use, especially in the case of high ambient temperatures.

c) Tie-down

In the case of a sailplane remaining rigged permanently, it is important that the maintenance program includes rust prevention for the fittings on fuselage, wings and tailplane.

Tie-down kits common in trade may be used to anchor the sailplane.

Dust covers should be regarded as essential for the sailplane.

d) Preparing for road transport

As the wing panels have a thin airfoil section, it is important that they are properly supported, i.e. leading edge down, with support at the spar stubs and at the outer portion in cradles of correct airfoil section.

The fuselage can rest on a broad cradle just forward of the u/c doors and on its tail wheel/skid.

The horizontal tailplane should be kept leading edge down in two cradles of correct airfoil section or placed horizontally on a padded support. On no account should the tailplane be supported by its fittings in the trailer.

8.5 Cleaning and care

Although the surface coating of a composite sailplane is robust and resistant, always take care of a perfect surface.

For cleaning and caring the following is recommended:

- Clean the surface (especially the leading edge of wing, horizontal stabilizer and fin) with clear water, a sponge and a chamois leather.
- Do not use too often rinsing additives common in trade.
- Polish and polishing materials may be used.
- Petrol and alcohol may be used momentarily only, thinners of all kinds are not recommended.
- Never use chlorine hydrogen (i.e. Tri, Tetra, Per etc.).
- The best polishing method is the buffing of the surface by means of an edge buffing wheel, fitted to a drilling or polishing machine. Thereby hard wax is applied to the rotating disc and distributed crosswise over the surface.

WARNING:

To avoid a local overheating, the buffing wheel should be moved constantly!

- The canopy should be cleaned with a plexiglass cleaner (e.g. "Mirror Glaze", "Plexiklar" or similar) and only if necessary, with warm water.

The canopy should be wiped down only with a soft clean chamois leather or a very soft material as used for gloves.

Never rub the canopy when it is dry !

- The sailplane should always be protected from the wet. If water has found a way in, the components should be stored in a dry environment and turned frequently to eliminate the water.
- The sailplane should not be exposed unnecessarily to intense sunlight or heat and should not be subjected to continual loads in a mechanical sense.

WARNING:

All external portions of the sailplane exposed to sunlight must be painted white - with the exception of the areas for the registration and anti-collision markings.

Colours other than white can lead to the CFRP/GFRP overheating in direct sunlight, resulting in an insufficient strength.

Section 9

9. Supplements

9.1 Introduction

9.2 List of inserted supplements

9.1 Introduction

This section contains the appropriate supplements necessary to safely and efficiently operate the sailplane when equipped with various optional systems and equipment not provided with the standard aircraft.

9.2 List of inserted supplements

Date	Section	Title of inserted supplement